



*An Online PDH Course
brought to you by
CEDengineering.com*

HVAC Hacks - Module 12: Space Heating Equipment & Systems - Essential Tips & Rules of Thumb

Course No: M08-025
Credit: 8 PDH

Anuj Bhatia



Continuing Education and Development, Inc.

P: (877) 322-5800
info@cedengineering.com

Table of Contents

1	CHAPTER -1: FORCED AIR HEATING SYSTEMS	1
1.1	How a Forced-Air Furnace Works	1
1.2	Main Components and Sizing Criteria	2
1.3	Furnace Capacity, Ratings, Size and Availability	3
1.4	Fuel Sources	4
1.5	Selection Criteria for Furnaces	6
1.6	Supply Air Temperatures and Airflow in Furnaces	10
1.7	Combustion Air	14
1.8	Ventilation for Combustion Air & Space Classification	20
1.9	Furnace Draft	25
1.10	Furnace Categories	27
1.11	Venting System	28
1.12	Initiating the Fire	35
1.13	High Efficiency Furnaces	37
1.14	Codes and Standards	39
1.15	Furnace Room Sizing	41
2	CHAPTER- 2: HYDRONIC HEATING SYSTEMS	46
2.1	Working of Hydronic Heating System	47
2.2	Water vs Air as a Heating Medium	48
2.3	Design Steps for Hot Water Heating System	49
2.4	Steam Boiler vs. Hot Water Boiler	54
2.5	Hot Water System Design Configurations	57
2.6	Classification of Hot Water Systems	59
2.7	Hot Water Supply Temperature for Space Heating	60

2.8	Boiler Input/Output Rating.....	60
2.9	Boiler Efficiency Ratings.....	62
2.10	Types of Boilers.....	64
2.11	Condensing and Non-Condensing Boilers.....	66
2.12	Boiler Draft.....	67
2.13	Boiler Room Ventilation and Smoke Exhaust.....	67
2.14	Boiler Room Sizing.....	74
2.15	Fuel Consumption.....	76
2.16	Boiler Control Strategies.....	77
2.17	Minimum Efficiency Requirements.....	78
3	CHAPTER – 3: HYDRONIC SYSTEM AUXILIARIES.....	79
3.1	Circulator Pumps.....	79
3.2	Pump Characteristics.....	83
3.3	Pumping Configurations.....	86
3.4	Pump Selection Criteria.....	88
3.5	Understanding Cavitation.....	89
3.6	Pump Affinity Laws.....	90
3.7	Pump Power Consumption.....	91
3.8	Meeting Efficiency Standards.....	93
3.9	Overview of Hydronic Piping.....	95
3.10	Pipe Sizing and Calculations.....	95
3.11	Pipe Sizing based on Velocity Criteria.....	96
3.12	Pipe Sizing based on Pressure Drop (Friction Loss) Method.....	98
3.13	Piping Design Configurations.....	104
3.14	Primary Secondary Piping.....	110

3.15	Piping Accessories (Valves)	116
3.16	Expansion Tanks	116
3.17	Air in Hydronic Heating Systems	119
3.18	Insulation.....	120
3.19	Heating Emitters (Terminal Units).....	121
3.20	Space Temperature Control Strategies.....	132
3.21	Energy Efficiency and Environmental Considerations	134
4	CHAPTER - 4: RADIANT FLOOR HEATING SYSTEM.....	136
4.1	Key Features of Floor Heating System	136
4.2	Design Steps.....	138
4.3	Manifold Placement and Setup	146
4.4	Floor Heating Installation - Pipe Placement and Concrete Reinforcement	147
4.5	System Costs	150
5	CHAPTER - 5: HEAT PUMP SYSTEMS	153
5.1	Type of Heat Pumps.....	155
5.2	Air Source Heat Pumps (ASHP).....	156
5.3	ASHP Design Configurations	157
5.4	Ground-Source (Geothermal) Heat Pumps (GSHP)	161
5.5	Water Source Heat Pump (WSHP)	163
5.6	Geothermal Piping Design Criteria.....	165
5.7	Geothermal System Design.....	167
5.8	Minimum Efficiency Requirements.....	171
	Course Summary....	172
	References	173
	ANNEXURE - 1: KEY RULES OF THUMB.....	174

Annexure -2: Vent Sizing Methodology for Natural Vent (Type B) Using NFPA 54..... 200

Annexure -2: Vent Sizing Methodology for Manifolded Multiple Vent System Using NFPA 54.....203

List of Equations

Equation 1. Estimating Airflow (CFM)	10
Equation 2. Boiler Fuel Consumption	76
Equation 3. Circulator Flowrate (GPM)	80
Equation 4. Flow rate vs. Pump Speed	90
Equation 5. Head pressure vs. Pump Speed.....	90
Equation 6. Power vs. Pump Speed	90
Equation 7. Pump Power (BHP)	91
Equation 8. Power Input	91
Equation 9. Power Consumption	92
Equation 10. Pipe Sizing on Velocity Criteria.....	96
Equation 11. Estimating Flowrate (Q)	97
Equation 12. Darcy-Weisbach Equation.....	99
Equation 13. Hazen-William’s Equation	99
Equation 14. Estimate Floor Surface Temperature.....	140
Equation 15. Calculate Coil/Roll Length for Underfloor/Radiant Heating	142
Equation 16. Estimating Flowrate (GPM)	143

List of Figures

Figure 1. Heating Furnace.....	1
Figure 2. Estimating Heat Output vs. Airflow Rate & Temperature Rise	10
Figure 3. Conventional Upflow Furnace	14
Figure 4. Combustion Air for Confined Spaces.....	22
Figure 5. Type of Furnace Vents	28
Figure 6. Hydronic Heat Emitters.....	46
Figure 7. Hydronic Heating Schematic.....	47

Figure 8. Forced Air Heating Schematic	57
Figure 9. Boiler Plant Room	74
Figure 10. End Suction, Split Casing and Vertical Inline Pumps.....	79
Figure 11. Pump Characteristic and System Curve	83
Figure 12. Circulator Pump Location Downstream of the Boiler.....	84
Figure 13. Nomograph for Carbon Steel Pipe Sizing	101
Figure 14. One Pipe System.....	104
Figure 15. Two Pipe System.....	105
Figure 16. Two Pipe Direct Return System	105
Figure 17. Two Pipe Reverse Return System	107
Figure 18. Two Pipe Hybrid System.....	108
Figure 19. Four Pipe Hybrid System	109
Figure 20. The Law of Tee	111
Figure 21. Types of Fan Coil Units	127
Figure 22. Hydronic Heating System Schematic.....	132
Figure 23. Radiant Floor Heating System.....	136
Figure 24. Air Source Heat Pump.....	153
Figure 25. Air Source Heat Pump Schematic Diagram	156
Figure 26. Heat Pump Operation	157
Figure 27. Indoor Split Unit Clearances	160
Figure 28. Outdoor Split Unit Clearances.....	161
Figure 29. Horizontal GSHP and Vertical GSHP.....	162
Figure 30. Water Source Heat Pump via Ground Water, Lake or Pond.....	163

List of Tables

Table 1. Sizing Criteria for Heating Furnaces	2
Table 2. Furnace Ratings and Availability	3
Table 3. Comparison of Fuels per 100,000 Btu of Heat Delivered	5
Table 4. Efficiency (AFUE) Classification of Heating Furnaces	7
Table 5. Supply Air Temperatures and Airflow	11
Table 6. Furnace Sizing for US Climate Zones	12

Table 7. Type of Air for Complete Combustion.....	14
Table 8. Rules for Perfect Combustion.....	17
Table 9. Excess Air vs. Excess Oxygen in Combustion Process.....	18
Table 10. Combustion Control Mechanisms	19
Table 11. Confined vs. Unconfined Spaces	20
Table 12. Combustion Air Openings – Confined Spaces	22
Table 13. Combustion Air Openings – Unconfined Spaces	23
Table 14. Furnace Drafts.....	26
Table 15. Furnace Categories	27
Table 16. Combustion Air vs. Venting System	28
Table 17. Direct Vent, Power Vent and Natural Vent	29
Table 18. Common Venting Configurations.....	29
Table 19. Venting System Types (Based on Furnace Category).....	30
Table 20. Vent Materials.....	31
Table 21. Dos and Don'ts for Single Vent System.....	32
Table 22. Dos and Don'ts for Multi-Vent System.....	33
Table 23. Initiating Combustion for Gas and Oil Furnaces	35
Table 24. Safety in Space Heating Furnaces	36
Table 25. High-Efficiency Furnaces for Space Heating.....	37
Table 26. Heating Furnaces , Minimum Efficiency Requirements, ASHRAE 90.1, Table 6.8.1-5	38
Table 27. NFPA 54 / IFGC Mandatory Requirements	39
Table 28. ANSI Z83.4 & Z83.18 - Emissions Requirements	40
Table 29. Typical Furnace Footprint by Capacity and Type	41
Table 30. Service Clearances for Furnaces.....	42
Table 31. Hydronic Heating (Boiler) vs. Forced Air Heating (Furnace).....	48
Table 32. Heat Loss Estimation based on Climate Zones	50
Table 33. Designing Hot Water Heating System.....	53
Table 34. Steam Boiler vs. Hot Water Boiler	55
Table 35. Hot Water Boiler vs. Hot Water Heater.....	56
Table 36. Hot Water Temperature Classification	59

Table 37. Standard Hot Water Supply Temperatures	60
Table 38. Boiler Ratings	61
Table 39. Boiler Efficiency.....	62
Table 40. Energy Efficiency in Boiler Selection	63
Table 41. Fire Tube Boilers	64
Table 42. Water Tube Boilers.....	65
Table 43. Fire Tube vs. Water Tube Boilers - Comparison.....	65
Table 44. Condensing Boilers vs Non-condensing Boilers	66
Table 45. Natural Draft vs. Mechanical Draft Boiler	67
Table 46. Ventilation Air vs. Exhaust Air	68
Table 47. Boiler Room Ventilation.....	69
Table 48. Codes/Standards for Ventilation Air.....	71
Table 49. Boiler Vent Categories.....	72
Table 50. Fuel Consumption per BHP Boiler Rating.....	76
Table 51. Boiler Control Strategies	77
Table 52. Boiler Efficiency Requirements (ASHRAE Std. 90.1).....	78
Table 53. GPM and Head Application Range of Different Pumps.....	80
Table 54. Pump Head Loss	82
Table 55. Pump Pressure vs. Head.....	82
Table 56. Pump Location	85
Table 57. Comparison Table of Pumping Configurations	87
Table 58. Selection Criteria for Pumps.....	88
Table 59. Tackling Cavitation.....	89
Table 60. Affinity Laws for Pumps	90
Table 61. The 3000 Rule for Estimating Pump HP	92
Table 62. ASHRAE 90.1 – 2019: Minimum Efficiency Requirements	93
Table 63. Recommendations for Right Pump Sizing.....	94
Table 64. Hydronic Piping Materials.....	95
Table 65. Recommended Velocity Limits	96
Table 66. Heating Loads and the Flowrates.....	97
Table 67. Allowable Pressure Drop	98

Table 68. Recommendations for Friction Loss Method	99
Table 69. Pipe Sizing Tables: Flowrates (GPM) at different Velocity and Pressure drop	102
Table 70. Direct Return Systems	106
Table 71. Reverse Return System.....	107
Table 72. Comparison: Two-Pipe vs. Four-Pipe Hybrid Systems.....	109
Table 73. Design Rules for Primary-Secondary Piping Configuration	115
Table 74. Expansion Tank Design	117
Table 75. System Volume for Heating Equipment.....	117
Table 76. System Volume in Piping	118
Table 77. Estimated System Volume – Rules of Thumb.....	118
Table 78. Air Elimination Devices	119
Table 79. Minimum Piping Insulation	120
Table 80. Radiator Output Ratings – What Affects Them?.....	122
Table 81. Radiator Classification – Cast Iron, Steel and Aluminum Types.....	123
Table 82. Convectors Sizing Factors	125
Table 83. Types of Convectors for Space Heating	125
Table 84. Design Factors for Fan Coil Units	127
Table 85. Types of Fan Coil Units.....	127
Table 86. Heat Emitter Sizing and Selection Criteria.....	130
Table 87. Pipe Sizing per Emitter Loop.....	131
Table 88. Installation Criteria for Heat Emitters	131
Table 89. Energy Efficiency in Hydronic Systems.....	134
Table 90. Radiant Floor System – Design Factors	137
Table 91. Ideal Floor Surface Temperature	139
Table 92. Pipe Sizing for Radiant Floor Heating.....	141
Table 93. Standard Pipe Sizes.....	141
Table 94. Pipe Spacing	141
Table 95. Supply Temperatures – Radiant Floor Heating	142
Table 96. Pressure Loss Criteria	144
Table 97. Floor Reinforcement	147
Table 98. Radiant Floor Insulation	148

Table 99. Ideal Floor Surface Temperature	149
Table 100. Radiant Floor Installation Guidelines	149
Table 101. Pros & Cons of Radiant Floor Heating.....	152
Table 102. Heat Pumps for Heating & Cooling.....	153
Table 103. Horizontal GSHP vs. Vertical GSHP System.....	162
Table 104. Open Loop vs. Closed Loop WSHP System	164
Table 105. HDPE Pipe Pressure Rating at Different Temperatures	165
Table 106. Pipe Sizes and Water Flow Rates (US GPM).....	166
Table 107. Conclusive Comparison of different Heating Systems.....	172

CHAPTER 1: FORCED AIR HEATING SYSTEMS

Forced Air Heating Systems are among the most widely used methods for space heating in residential, commercial, and light industrial buildings. These systems operate by heating air in a central unit, typically using a furnace, heat pump, or electric heater, and distributing the warm air through ducts by a blower. When fossil fuels are used, combustion gases are exhausted through flue vents, while electric furnaces need no chimney but cost more to run.

This chapter focuses on fossil fuel furnaces due to their economic advantage and broad application. Their key advantages include rapid temperature response, easy filtration for improved indoor air quality, and compatibility with modern thermostatic and zoning controls.

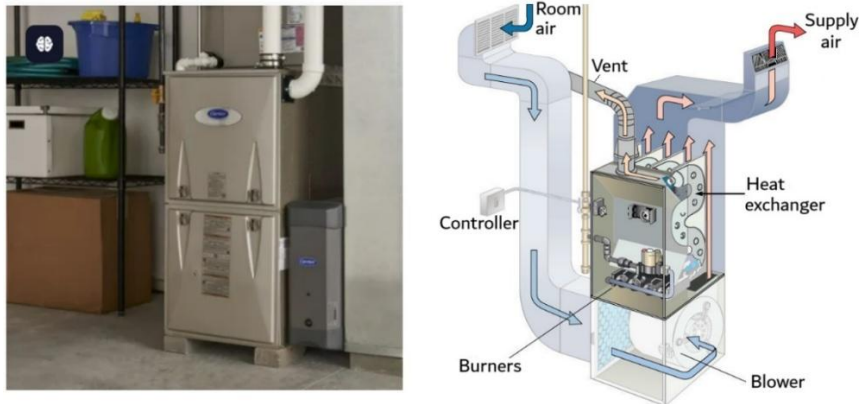

Figure 1. Heating Furnace

How a Forced-Air Furnace Works

- a. Heat Generation – Burns fuel or uses electricity to create heat.
- b. Heat Exchange – Transfers heat to the air via a heat exchanger.
- c. Air Distribution – Blower circulates warm air through ductwork.
- d. Return Cycle – Cooler air returns via ducts to repeat the process.

Key Advantages and Disadvantages

Advantages (✓)

- Quick heating
- Integrates with air conditioning for cooling
- Energy-efficient models available
- Compatible with smart thermostats.

Disadvantages (✗)

- Requires ductwork (costly to install). Zone control is difficult and complex
- Can dry indoor air without a humidifier
- Spread dust/allergens if filters are not cleaned regularly
- Fuel systems need ventilation and safety precautions.

Main Components and Sizing Criteria

The table below summarizes key components of a natural gas furnace, their functions, and basic sizing guidelines.

Table 1. Sizing Criteria for Heating Furnaces

Component	Function	Rules of Thumb
Burner	Burns fuel to generate heat	Size to meet or slightly exceed heating load (Btu/h). Example: 90% efficient furnace delivering 90,000 Btu/h → needs ~100,000 Btu/h burner input.
Heat Exchanger	Transfers combustion heat to air	0.8–1.2 ft ² surface area per 10,000 Btu/h.
Blower / Fan	Circulating heated air through ductwork	Heating: 150–160 CFM per 10,000 Btu/h (≈ 60°F rise). Cooling: 400 CFM per ton (12,000 Btu/h) with ≈ 20°F drop.
Fuel Supply	Delivers gas or oil to burner	100 ft ³ natural gas ≈ 100,000 Btu/h; 1 gal fuel oil ≈ 140,000 Btu.
Manifold	Distributes fuel evenly to burners	1–2 in diameter for 50,000–100,000 Btu/h.
Regulator & Controls	Maintain fuel flow and pressure	Set to 3.5–11 in. WG (water gauge).
Igniter	Starts combustion	Hot Surface Igniter (HSI), most common in modern furnaces (100–300W) or Direct Spark Ignition (DSI) that uses a high-voltage spark to ignite gas.
Combustion Chamber	Contains combustion process	~0.01–0.02 ft ³ per 1,000 Btu/h input.
Thermostat	Controls operation by room temperature	1°F buffer; one thermostat per zone.
Flue / Vent	Exhausts combustion gases outdoors	1 in ² vent area per 4,000–5,000 Btu/h.

Component	Function	Rules of Thumb
Air Filter	Cleans circulating air	~1 ft ² filter area per ton; replace every 1–3 months.

Design Guidelines



- Furnace Sizing: Match furnace output to building heating load , typically 20–60 Btu/h per ft² of floor area (varies by climate and insulation).
- Efficiency Range: Choose furnaces with 80–95% AFUE (Annual Fuel Utilization Efficiency) for optimal performance and energy savings.

Furnace Capacity, Ratings, Size and Availability

Furnace Capacity is the heat output in Btu/h, typically 40,000–120,000 Btu/h for residential homes and up to 1 million+ Btu/h for commercial use. It must match the building's heat loss for optimal comfort and efficiency.

- Ratings: Measured in Btu/h or MBH (1 MBH = 1,000 Btu/h), with AFUE (80–98%) indicating efficiency. Higher outputs suit colder climates or larger spaces.
- Size: Refers to both physical cabinet width (e.g., cabinet width: 14.0, 17.5, 21, 24.5 inches) and output. Ensure furnace sizing align with ductwork and space fitment.
- Availability: Depends on fuel type (gas, oil, electric), efficiency level (standard or high), and configuration (single/two-stage, modulating). Gas furnaces dominate urban areas, oil in rural settings, and electric where fuel access is limited.

Table 2. Furnace Ratings and Availability

	Parameters	Rules of Thumb
	Rating (Btu/h)	30-60 Btu/h/ft ² (moderate to cold climates); adjust for insulation.
	Capacity	Match to heat loss: 80-100% of peak load; +10-15% buffer.
	Availability	Gas: 40,000-120,000 Btu/h (residential) and up to 1 million Btu/h for commercial applications. All fuels.

Fuel Sources

Most furnaces run on natural gas, fuel oil, or liquefied petroleum gas (LPG). The heat content of these fuels is shown in the table below.

Parameters	LPG (Propane)	Natural Gas (Methane)	Fuel Oil (#2)
Heat Content (approx.)	<ul style="list-style-type: none"> • 91,500 Btu/gal • 21,500 Btu/lb 	<ul style="list-style-type: none"> • 1,030 Btu/ft³ • 37,700 Btu/lb • 100,000 Btu/Therm 	<ul style="list-style-type: none"> • 139,000 Btu/gal • 19,500 Btu/lb
Air-fuel ratio	9.5:1	10:1	14:1
Commercial Comparison (varies by region/time)	~\$2.50/gal	~\$1.50/Therm	~\$3.50/gal
Heating Area Coverage	1 lb heats ~400–500 ft ²	1 Therm heats ~1,500–2,000 ft ²	1 gal heats ~2,000–2,500 ft ²
Delivery/Storage	Stored in pressurized tanks	Piped utility service	Stored in large tanks
System Notes	Good for rural/off-grid homes	Cleanest fossil fuel, low emissions	High maintenance, soot buildup and burner tuning.

Notes:

- Efficiency: Assumes 80-95% AFUE for furnaces; oil may drop to 70-85% if poorly maintained.
- Heat Output: 30-60 Btu/h/ft² typical for sizing (varies by climate/insulation).
- Combustion: All require venting; oil needs more frequent chimney cleaning.
- Costs: Vary by region (2025 estimates); NG cheapest where piped, LPG/oil for off-grid.
- 1 Therm \approx 100,000 Btu \approx 2.83 m³ of natural gas
- Pressure regulator needed to allow the LPG to return to a gaseous state before entering the furnace.

1.1.1 Operating Costs with Different Fuels

To conduct a fair techno-commercial comparison of fuels, an apples-to-apples approach is essential, achieved by converting each fuel’s heat content into Btu and evaluating costs on a standardized basis. The objective is to determine the cost per 100,000 Btu of heat delivered, factoring in a typical furnace efficiency of 85%.

Table 3. Comparison of Fuels per 100,000 Btu of Heat Delivered

Fuel Type	Cost per Unit	Heat Content per Unit	Effective Heat (Btu) at 85% Efficiency	Cost per Btu (\$)	Cost per 100,000 Btu (\$)
LPG (Propane)	\$2.50/gal	91,500 Btu/gal	77,775 Btu/gal (91,500 × 0.85)	\$0.032 (\$2.50 ÷ 77,775)	\$3.20 (\$0.032 × 100,000)
Natural Gas	\$1.50/Therm	100,000 Btu/Therm	85,000 Btu/Therm (100,000 × 0.85)	\$0.0176 (\$1.50 ÷ 85,000)	\$1.76 (\$1.50 ÷ 0.85)
Fuel Oil #2	\$3.50/gal	139,000 Btu/gal	118,150 Btu/gal (139,000 × 0.85)	\$0.030 (\$3.50 ÷ 118,150)	\$3.00 (\$0.030 × 100,000)

Results: Natural gas is the cheapest at \$1.76, followed by fuel oil at \$3.00, and LPG at \$3.20 per 100,000 Btu delivered.

Notes: Costs are 2025 estimates; efficiency adjusts usable heat output. Natural gas benefits from direct Therm pricing (1 Therm = 100,000 Btu), simplifying its calculation.

Selection Criteria for Furnaces

Furnaces for space heating systems are selected based on fuel type, efficiency, configuration, airflow direction, and heat transfer method. Here's a brief overview:

Fuel Types

Furnace utilizes standard fuels - natural gas, LPG (propane), fuel oil, and electricity, each with distinct characteristics.

- a. Natural Gas: Clean, cost-effective, and ideal for urban areas (heat energy = 1,030 Btu/ft³).
- b. LPG (Propane): Portable, efficient, suitable for remote sites without piped gas connection (heat energy = 91,500 Btu/gal).
- c. Fuel Oil: Delivers high energy content but requires storage and produces more emissions (heat energy = 139,000 Btu/gal).
- d. Electric: Safe and simple, suited for small or mild-climate areas despite higher cost (heat energy = 3,412 Btu/kWh).

Fuel choice depends on local access, cost, and heating needs.

Furnace Classification on Efficiency



Furnace efficiency measures how effectively fuel is converted to heat, primarily using a term AFUE (Annual Fuel Utilization Efficiency), as defined by ASHRAE. It reflects seasonal average heating efficiency, for example, 80% AFUE means 80% of fuel becomes heat, while 20% is lost. AFUE helps compare costs and efficiency across systems but excludes electricity use for fans.

There are three types of furnace classifications.

- a. Standard Efficiency: 70–85% AFUE. Recommended for mild climate zones.
- b. Mid-Efficiency: 85–89% AFUE. Recommended moderate climate zones.
- c. High Efficiency: 90–98% AFUE. Recommended for cold/severe cold climate zones.

These metrics help optimize system selection for energy and cost efficiency.

Table 4. Efficiency (AFUE) Classification of Heating Furnaces

	Classification	Rules of Thumb				
		AFUE	Heat Exchanger	Venting	Stack Temp.	Sizing Guideline
	Standard Efficiency	70–85%	Single heat exchanger	Natural draft, chimney. Sizing: 1 in ² per 4,000 Btu/h)	High: 300-400°F	Size 10-20% above peak load.
	Mid-Efficiency	85–89%	Single enhanced heat exchanger	Induced draft blower, Sizing: 1 in ² per 4,500 Btu/h)	Moderate: 150-200°F	Size at peak load
	High-Efficiency	90–98%	Condensing furnace with dual secondary heat exchanger	Forced draft, PVC vent, Sizing: 1 in ² per 5,000 Btu/h)	Low: 100-120°F	Size at peak load

Notes

- Relevance: AFUE guides furnace selection for efficiency, cost, and climate suitability.
- Comparison Focus: Efficiency increases left to right, with design complexity and cost rising accordingly.
- Adjustments: Match furnace type to climate severity, budget constraints, and building infrastructure. Add 10-15% buffer to capacity.
- Sizing Impact Oversizing >20% reduces efficiency 5–10% due to short cycling.
- Climate Matching: 80% AFUE for mild (Zone 3); 90–95% for cold (Zone 5); adjust for insulation.
- Requirements: Minimum AFUE: 78% (U.S. federal); Local standards vary from state to state. High efficiency furnaces with a minimum AFUE of 90 percent is recommended in northern US states despite high upfront costs.
- Cost vs. Savings: High AFUE (90%+) costs 20–30% more but cuts fuel use 15–25% yearly.

Other Furnace Efficiency Terms

Efficiency Type	Description	Relevance
Combustion Efficiency	Measures how well fuel is burned, based on exhaust temperature and CO ₂ /O ₂ levels.	Indicates fuel use effectiveness during combustion.
Thermal Efficiency	Measures heat transfer from combustion to air via exchanger surfaces.	Affects heat delivery rate and comfort.
Distribution Efficiency	Evaluates how well heat is delivered to rooms through ducts or other systems.	Ensures even heating and minimizes energy loss.

Furnace Design Configuration

Furnace configurations define how heat is delivered, and output is controlled for space heating:

- Single-stage: Single-stage furnaces operate at a fixed, full-capacity output, cycling on and off to maintain temperature. Best for stable and consistent climates.
- Two-stage: Switches between low and high output (e.g., 60–100%) for better comfort and efficiency.
- Modulating: Adjusts the output continuously (e.g., 40–100%) for precise control, energy savings, and consistent comfort, ideal for varying conditions or fluctuating climates.

Each option offers trade-offs in cost, performance, and efficiency.

Airflow Direction

Airflow mechanisms in furnaces, up flow, downflow, and horizontal, determine how heated air is distributed in a building.

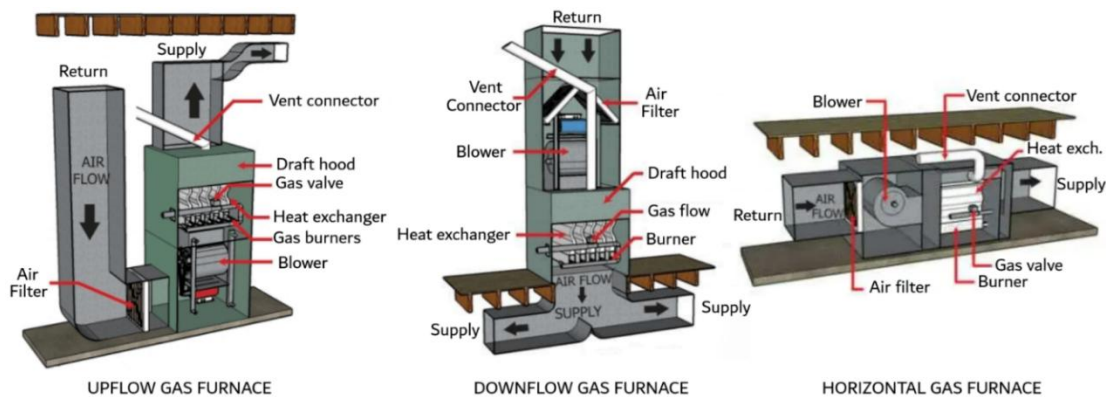

- a. Up flow Furnace: Typically, installed in basements; draws air from below and pushes heated air upward.
- b. Downflow Furnace: Located in attics or upper floors; pulls air from above and sends heat downward.
- c. Horizontal Furnace: Installed sideways and typically used in low-clearance spaces like attics or crawl spaces. These draw air from one side, heat it, and expel it horizontally through ducts offering flexibility in constrained installations.

Each configuration aligns with specific building layouts and space limitations. The main thing you'll have to think about is the furnace's installation location.

Heat Transfer Method

Furnaces heat spaces through distinct mechanisms: direct-fired, indirect-fired, and radiant heating.

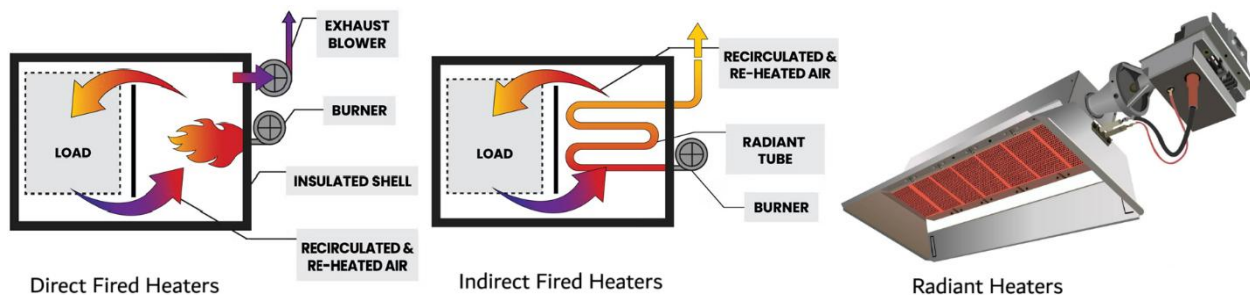

- a. Direct-fired heaters heat air by burning fuel directly in the airstream, best for large, ventilated, unoccupied spaces like warehouses.
- b. Indirect-fired heaters use a heat exchanger to keep combustion gases separate and therefore improve air quality and make them safe for homes and occupied spaces.
- c. Radiant heaters emit infrared energy to heat objects and people directly. Efficient for spot heating in open industrial spaces.

Each method suits specific applications based on efficiency, safety, and space requirements.

Supply Air Temperatures and Airflow in Furnaces

Supply air temperature refers to the heated air leaving the furnace and entering the living space through ducts, typically measured at supply registers. It depends on furnace size, heat exchanger efficiency, and airflow rate. For gas furnaces, the typical supply air temp. is 104–122°F, though ASHRAE and manufacturer specs allow up to 140°F, depending on climate and system design. With return air (recirculated air) temperatures around 65–70°F, this results in a 35–70°F rise for a 100–140°F supply air furnace.

Equation 1. Estimating Airflow (CFM)

Airflow (cubic feet per minute, CFM) is estimated using the heat output and temperature rise:

$$\text{Airflow (CFM)} = \frac{\text{Heat output (Btu/h)}}{[1.08 \times (\text{supply air temp. (}^\circ\text{F)} - \text{return air temp. (}^\circ\text{F)}]}$$

Example

Heat Output: 60,000 Btu/h (furnace capacity).

Supply Air Temp: 120°F.

Return Air Temp: 70°F.

ΔT : 120°F - 70°F = 50°F.

The Figure below can be used to estimate heat required to airflow rate and temperature-rise.

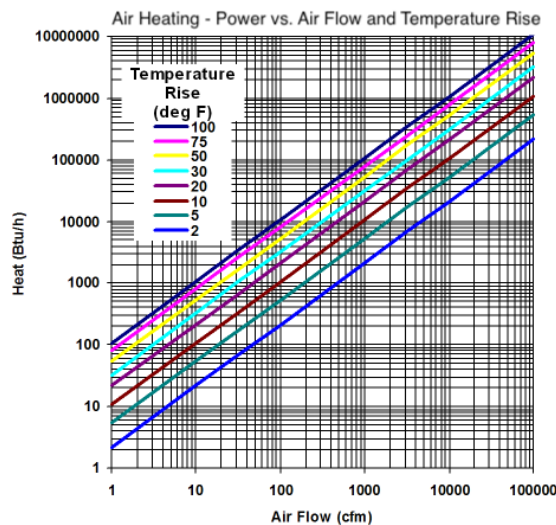







Figure 2. Estimating Heat Output vs. Airflow Rate & Temperature Rise

Table 5. Supply Air Temperatures and Airflow

	Parameters	Rules of Thumb
	Supply Air Temp	104-122°F standard; 100-140°F max. (ASHRAE)
	Temperature Rise (ΔT)	<p>Temperature rise (ΔT) is the difference between the supply air temperature and the return air temperature in a forced-air furnace system. It indicates how much the air is heated as it passes through the furnace.</p> <p>$\Delta T = T_{\text{supply}} - T_{\text{return}}$</p> <p>Typical Range:</p> <ul style="list-style-type: none"> • Gas and oil furnaces: 40–60°F • Acceptable range: 30–70°F • Recommended: 40–50°F for efficient and safe operation.
	Consequences of Low ΔT	<p>Low ΔT (Too Little Temperature Rise):</p> <ul style="list-style-type: none"> • Indicates excessive airflow or insufficient heat transfer. • Air passes too quickly over the heat exchanger, picking up less heat. • Can cause cool drafts from supply registers. • In condensing furnaces, too low a rise may prevent proper condensation, reducing efficiency.
	Consequences of High ΔT	<p>High ΔT (Too Much Temperature Rise):</p> <ul style="list-style-type: none"> • Indicates insufficient airflow or blocked ducts/filters. • Air stays too long in the heat exchanger, overheating it. • Can lead to heat exchanger damage and high-limit switch trips (safety shutdown).
	Recirculation Air Temp	65-70°F; maintain for efficiency.
	Airflow (CFM)	<p>≈ 310 CFM per 10,000 Btu/h for 30°F temperature rise (ΔT).</p> <p>≈ 185 CFM per 10,000 Btu/h for 50°F temperature rise (ΔT).</p> <p>≈ 130 CFM per 10,000 Btu/h for 70°F temperature rise (ΔT).</p>

1.1.2 Furnace Sizing

Furnace sizing depends on several key factors:

- a. Climate Zone: Colder climates zones (5 to 8) require higher heating capacities.
- b. Building Construction: Well-built, tight structures with air sealing and minimal thermal bridging need less heating compared to older or poorly constructed buildings.
- c. Insulation Levels: Higher R-values in walls, roofs, and floors significantly reduce heat loss, lowering furnace capacity needs.
- d. Air Infiltration: Buildings with air leaks or unsealed ducts lose heat quickly. Reducing infiltration can cut furnace sizing requirements by up to 20%.
- e. Window Performance: Double/triple-pane, low-E windows reduce heat loss; older single-pane windows increase demand.
- f. Ceiling Height & Layout: Tall ceilings and open floor plans may require adjustments to basic sizing rules to account for stratification and circulation.
- g. Occupancy and Internal Gains: In some cases, heat generated by people, lighting, and equipment offsets heating loads.

Table 6. Furnace Sizing for US Climate Zones

Climate Zone	General Climate Description	Typical Heat Loss Range (Btu/h·ft ²)	Heat Loss Considerations
Zone 1 (Miami, FL)	Hot, Humid	5-10 Btu/h·ft ²	Minimal heating needed; Cooling dominated, focus on minimizing solar heat gain.
Zone 2 (Houston, TX)	Warm, Humid	10-15 Btu/h·ft ²	Mild winters, low heating demand.
Zone 3 (Atlanta, GA)	Hot-Dry/Mixed-Humid	15-25 Btu/h·ft ²	Moderate heating; wide temperature swings in dry climates.
Zone 4 (Washington, D.C.)	Moderate Climate	20-35 Btu/h·ft ²	Moderate heating; varying humidity levels.
Zone 5 (Chicago, IL)	Cool Climate	30-50 Btu/h·ft ²	Significant heating load; insulation is crucial.
Zone 6 (Minneapolis, MN)	Cold Climate	40-60 Btu/h·ft ²	High heating load; very cold winters.
Zone 7 (Denver, CO)	Very Cold	50-70 Btu/h·ft ²	Very high heating load; extremely cold.
Zone 8 (Anchorage, AK)	Subarctic/Arctic	70-100+ Btu/h·ft ²	Extreme heating load; severe winters.

Notes:

- Rule of Thumb: Average 30–60 Btu/h per ft² (gas); 10–15 watts/ft² (electric) – for rough estimates only. Perform detailed load analysis using ACCA Manual J or ASHRAE methods for final equipment sizing. Note that over-sizing leads to short-cycling, discomfort, and higher operating costs, while under-sizing can leave spaces cold in peak conditions.
- Elevation Adjustment: Derate 4% per 1,000 ft above sea level (e.g., 10% less capacity at 2,500 ft); adjust burner for thin air. Example: 100,000 Btu/hr (rated capacity) → ~80,000 Btu/hr (delivered capacity) at 5,300 ft in Denver, USA. Check manufacturer derating curves above 2,000 ft.

Combustion Air

Combustion air is the air needed for burning fuel (gas or oil) in a furnace. It ensures complete combustion for efficient heat, producing carbon dioxide (CO₂) and water vapor as byproducts while minimizing harmful gases like carbon monoxide (CO).

Example: 1 ft³ of natural gas needs ~10 ft³ of air for proper combustion.

Combustion air types include:

- Primary air – mixes directly with fuel
- Secondary air – supports complete combustion
- Excess air – added to ensure full combustion
- Dilution air – cools and clears exhaust gases

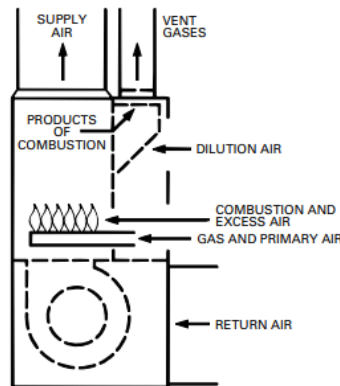





Figure 3. Conventional Upflow Furnace

Table 7. Type of Air for Complete Combustion

	Air Type	Function	Rules of Thumb
	Primary Air	Mixed with fuel before ignition to initiate combustion; controls burn rate.	Use 5–7 ft ³ air per ft ³ gas. Too little = CO; too much = heat loss.
	Secondary Air	Supplied around the flame to complete combustion.	Aim for 8–12% CO ₂ in flue. Not needed for power burners.
	Excess Air	Air beyond stoichiometric needs to ensure complete burning.	Target 20–30%; reduce with good burner tuning.
	Dilution Air	Added at vent outlet to cool flue gases, manage draft, and prevent condensation.	1–2 ft ³ per ft ³ flue gas for 300–400°F exhaust. Minimal in condensing systems.

Notes:

- Units: Air in ft³ per ft³ fuel (gas) or gal (oil); CO₂ in flue gas (%).
- Relevance: Primary/secondary balance efficiency; excess ensures safety; dilution aids venting.
- Adjustments: Tune via burner settings and draft (e.g., 10:1 total air-to-gas ratio).

1.1.3 Stoichiometric Combustion

Stoichiometric combustion occurs when fuel burns with exactly the right amount of oxygen, no more, no less, producing only carbon dioxide (CO₂), water vapor (H₂O), and heat. This process leaves no unburned fuel, excess oxygen, carbon monoxide (CO), or soot, achieving maximum energy output with zero excess air.

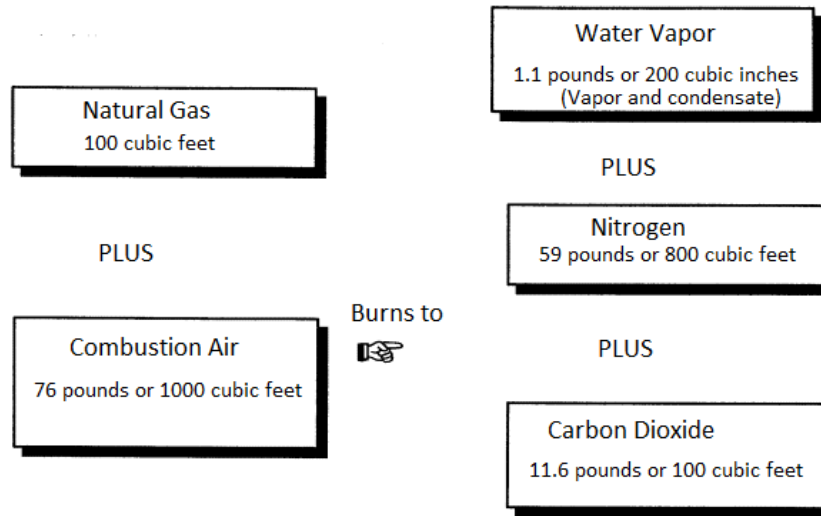

Stoichiometric combustion is a theoretical ideal condition, but in real-world applications, it is unsafe. Even minor fluctuations in air or fuel can lead to incomplete combustion - producing CO, soot, and unburned fuel, which pose efficiency and safety risks. To avoid this, a small, controlled amount of excess air is introduced to ensure complete combustion and reliable operation. The practical combustion process with excess air is shown below.

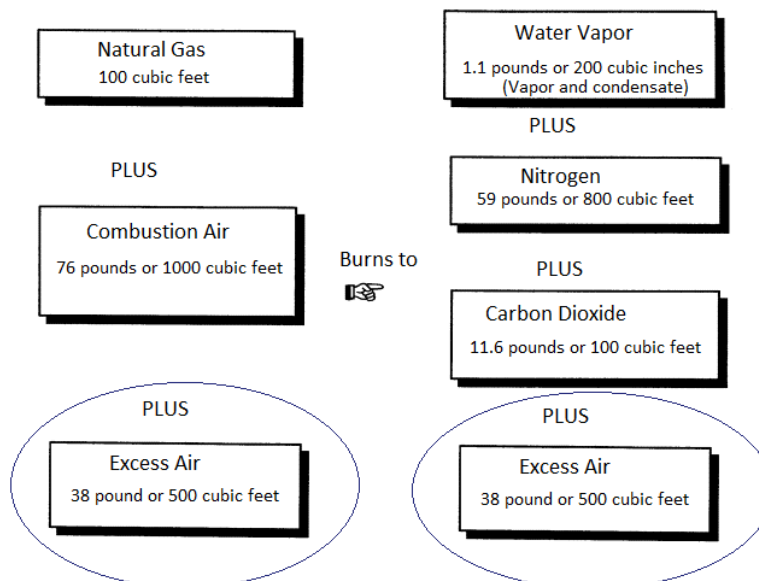

Impact of Air-Fuel Ratio and Excess Air in Combustion

The air-fuel ratio plays a critical role in combustion performance, influencing efficiency, emissions, and safety:

- Too little air causes incomplete combustion, leading to carbon monoxide (CO), soot, and unburned fuel, posing serious health and safety risks.
- Too much air cools the flame, increases heat loss through exhaust, and reduces thermal efficiency.

A balanced approach typically targets around 10-20% excess air to achieve safe, complete combustion while maintaining high efficiency.

Table 8. Rules for Perfect Combustion

Fuel Type	Air Requirement	Flue Gas Targets			Heat Content
		CO ₂ (%)	O ₂ (%)	CO (%)	
Natural Gas	10 ft ³ air/ft ³ gas (10:1)	14–15%	0%	0%	~1,030 Btu/ft ³
LPG (Propane)	25 ft ³ air/ft ³ LPG (25:1)	13–14%	0%	0%	~91,500 Btu/gal OR ~2,500 Btu/ft ³
Fuel Oil #2	1,400 ft ³ air/gal oil	12–13%	0%	0%	~139,000 Btu/gal

Notes

- Regardless of the fuel, 1 cubic foot of air is typically required for every 100 Btu of energy released from combustion.
- Flue Gas: Perfect = max CO₂, no O₂/CO; real-world targets 10-12% CO₂, 2-5% O₂.

1.1.4 Excess Air and Excess Oxygen







Excess air and excess oxygen are not the same. Excess air refers to all the air supplied beyond the stoichiometric requirement, while excess oxygen is the unused O₂ measured in flue gases. Since air is about 21% oxygen, 10% excess air corresponds to roughly 2–3% O₂, and 50% excess air ≈ 10.5% O₂.

- Excess Air: Total air added above the theoretical need to ensure full combustion, expressed as a % of stoichiometric air (e.g., 10% excess = 110% of required air).
- Excess Oxygen: Unused O₂ in flue gases, indicating surplus air. Typically, 2–5% by volume and used to verify complete combustion.

Relation: 10% excess air ≈ 2% excess O₂ in flue (varies by fuel).

Measurement: Excess O₂ tested via flue gas analysis; excess air calculated from O₂ and fuel type.

Table 9. Excess Air vs. Excess Oxygen in Combustion Process

	Description	Excess Air	Excess Oxygen
	Definition	Total extra air above stoichiometric need.	Unreacted O ₂ in flue gas post-combustion.
	Units	% of stoichiometric air (e.g., 10-50%).	% of flue gas volume (e.g., 2-5%).
	Purpose	Ensures complete burn, prevents CO.	High percentage of O ₂ in the exhaust indicates lower efficiency.
	Typical Range	10-20% for optimum efficiency.	2-5% ideal; >6% signals too much air.
	Rule for Gas	11-13 ft ³ /ft ³ (10-30% excess).	3-4% O ₂ in flue; CO <50 ppm.
	Rule for LPG	26-31 ft ³ /ft ³ (10-30% excess).	2-3% O ₂ in flue; CO <50 ppm.
	Rule for Oil	15.8-18.7 ft ³ /gal (10-30% excess).	4-5% O ₂ in flue; CO <100 ppm.

1.1.5 Combustion Controls

Combustion controls regulate the fuel and air supply in furnaces to maintain efficient, complete combustion. They adjust the air-fuel ratio using burners, valves, and draft systems (natural, induced, or forced), responding to load, temperature, and flue gas readings (O₂, CO).

Key point: You can't control what you don't measure.

Measuring O₂ (or CO₂) using simple gas analyzers is essential for proper tuning and heat transfer, directly impacting combustion efficiency. Standard graphs below illustrate how correct tuning enhances heat transfer and overall efficiency.

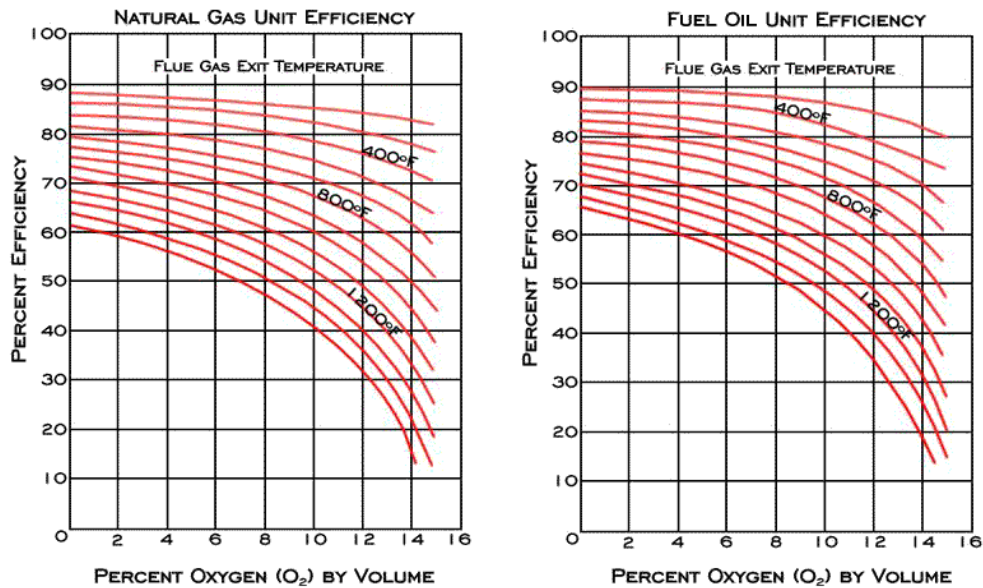





Table 10. Combustion Control Mechanisms

	Furnace Type	Rules of Thumb
	Single Stage	ON/OFF type gas valve. Needs 10–20% excess air ≈ 2–5% O ₂ in flue. Good for small systems.
	Two Stage	High/low settings (60–100%) with dual valves. Target 10–15% excess air ≈ 2–4% O ₂ in flue. Good for mid-size units.
	Modulating	Variable output (40–100%) with dynamic fuel-air mix via thermostat. Target 10–15% excess air ≈ 2–3% O ₂ . Ideal for large or precise systems.

Notes:



- Regulation: Single stage is simplest; two-stage type improves flexibility; modulating type offers precision.
- Adjustment: Use flue gas analysis (O₂/CO) to set air-fuel ratios; aim for CO <50 ppm.

Ventilation for Combustion Air & Space Classification

Combustion air ventilation needs depend on whether the appliance is in a confined or unconfined space:

- a. Confined Space: A space less than 50 ft³ volume per 1,000 Btu/h input.
- b. Unconfined Space: A space with more than 50 cubic feet per 1,000 Btu/h of appliance input.

Table 11. Confined vs. Unconfined Spaces

	Space Type	Rule of Thumb
	Confined Space	Requires extra ventilation openings for combustion air.
	Unconfined Space	No extra air or openings are needed (e.g., basements, large rooms).

How to determine a Confined Space

To determine whether a room is a confined space, perform the following steps:

- a. Total the gas input ratings of all the gas appliances in the space in Btu/h.
- b. Determine the volume of the utility room.
- c. Check if a minimum of 50 cubic feet of volume is available for every 1,000 Btu of fuel input.

Example:

A room 12' x 20' x 10' (H) contains a gas water heater with 40,000 Btu/h input and a furnace with 80,000 Btu/h input.

Total fuel input = 40000 + 80000 = 120,000 Btu/h.

At 50 cubic feet per 1000 Btu/h input, the minimum room volume required to preclude the space being classified as a confined space is:

$$\frac{50}{1000} \times 120000 = 6000 \text{ ft}^3$$



Utility room volume = 12' x 20' x 10' = 2400 ft³.

Result: Since the utility room is under 6,000 ft³, it qualifies as a confined space, and you will need to make provision for the additional ventilation openings for more combustion air. Alternatively, the room would need to be at least 600 ft² with a 10 ft ceiling, or 500 ft² with a 12 ft ceiling as mandated by the codes.

Rules for Confined Spaces

Combustion air requirements and installation guidelines are detailed in the National Fuel Gas Code (NFPA 54/ANSI Z223.1-1999) and the International Fuel Gas Code (IFGC). According to these codes, furnaces can draw combustion air from either within the heated space (indoor air) or from outside (direct vent), depending on the space classification and ventilation provisions.

Table 12. Combustion Air Openings – Confined Spaces

	Scenario	Rules of Thumb	
		Opening Location	Minimum Free Area
	Confined Space – Inside Air	Two openings: one high, one low within 12" of ceiling & floor.	1 in ² per 1,000 Btu/h, minimum 100 in ² per opening (e.g., 100,000 Btu/h → 2 × 100 in ²).
	Confined Space – Outdoor Air, Vertical Duct	Two openings: one high, one low within 12" of ceiling & floor.	1 in ² per 4,000 Btu/h per opening (e.g., 100,000 Btu/h → 25 in ²)
	Confined Space – Outdoor Air, Horizontal Duct	Two openings: one high, one low within 12" of ceiling & floor.	1 in ² per 2,000 Btu/h per opening (e.g., 100,000 Btu/h → 50 in ²).

Sealed combustion draws air directly from outdoors via a dedicated plastic pipe, isolating the combustion process from indoor air. This method improves safety and efficiency by preventing flue gas leaks into occupied space. However, it requires precise installation per manufacturer guidelines due to its closed design. Refer figures below:

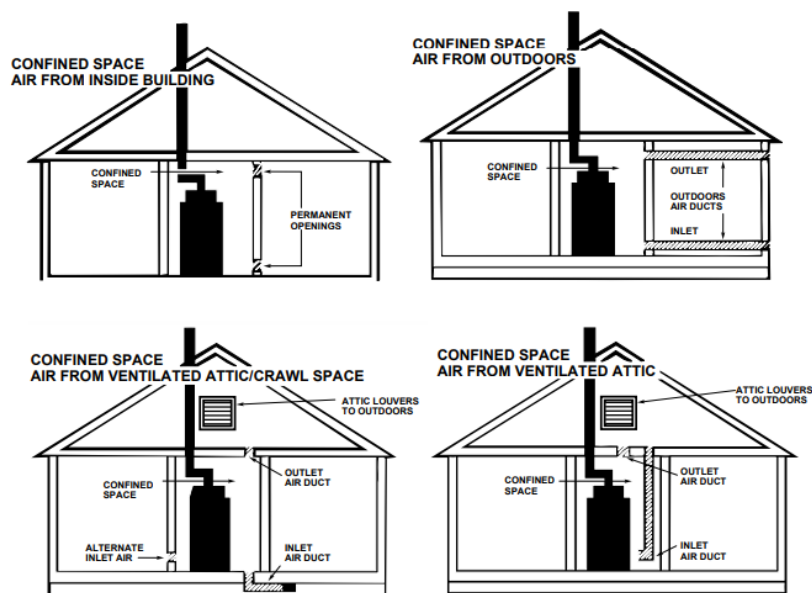

Figure 4. Combustion Air for Confined Spaces

1.1.6 Free Area of Intake Louver

Free Area refers to the net open area available for airflow after deducting blockage from louvers, grilles, or screens. Undersized openings can cause poor ventilation and CO buildup.

Louver Type	Typical Free Area	Example (10"×10")
Metal	~60%	100 in ² → 60 in ² net
Wood	20–25%	100 in ² → 20–25 in ² net

Example: To achieve 100 in² net free area, use:

167 in² metal (100 ÷ 0.6)

400 in² wood (100 ÷ 0.25)

1.1.7 Rules for Unconfined Spaces

Unconfined spaces usually don't require outside air. However, in tightly sealed buildings (with heavy insulation, vapor barriers, gasketed windows/doors), outside air may be needed to prevent negative pressure. In such cases, follow the same intake guidelines used for confined spaces.

Table 13. Combustion Air Openings – Unconfined Spaces

	Scenario	Rules of Thumb	
		Opening Location	Minimum Free Area
	Unconfined Space	No additional openings required	50 ft ³ per 1,000 Btu/h

1/20 Rule for Confined vs. Unconfined Spaces

To determine if a space is confined space or unconfined space:

- a. Add total Btu/h input of all appliances.
- b. Divide by 20.
- c. Compare with the room volume (ft³).
 - If room volume < result, it's a confined space → needs extra combustion air.
 - If room volume ≥ result, it's unconfined → no extra air needed.

Example

Consider a combustion appliance zone (CAZ) that measures 10' L x 14' W x 8' H. The appliances in space include a gas furnace at 75,000 Btu/h input, a hot water heater at 40,000 Btu/h input, and a gas dryer at 125,000 Btu/h input.

CAZ volume = $10 \times 14 \times 8 = 1,120$ cubic feet.

The total appliance input = $75000 + 40000 + 125000 = 240,000$ Btu/h.

Applying the 1/20 rule:

Result: Since $1,120 \text{ ft}^3 < 12,000 \text{ ft}^3 \rightarrow$ confined space \rightarrow provide extra combustion air.

Furnace Draft

Furnace draft is the pressure difference that moves combustion air in and flue gases out of the furnace, it's the driving force behind venting.

Why it's needed:

- Safety: Removes harmful gases like CO
- Efficiency: Supplies enough air for full combustion, maximizing fuel use and heat
- Performance: Prevents flame issues and backdraft





Draft and venting are related but distinct: draft is the force (like an engine), and the venting system is the flow path that channels the gases (pipes, stack etc.). For example, a Type B vent (mechanism) relies on natural draft (buoyancy) to function. They work together, draft is the engine (powers the vent), venting is the vehicle.

Furnace Draft Types

Draft is measured in inches of water gauge (in. WG) and varies by furnace design:

- a. Natural Draft: Relies on the buoyancy of hot gases rising through a chimney.
 - Pressure: -0.02 to -0.05 in. WG
 - Factors: It depends on chimney height (taller = stronger draft), gas temperature (hotter = better draft), and ambient conditions (colder outdoor air = greater draft).
- b. Induced Draft: Uses a blower to pull flue gases out, creating negative pressure.
 - Pressure: -0.05 to -0.1 in. WG
 - Typical in mid-efficiency (80–89% AFUE) units
- c. Forced Draft: Blower pushes air into combustion chamber, boosting pressure and efficiency.
 - Pressure: $+0.05$ to $+0.2$ in. WG
 - Used in high efficiency/industrial units; airtight venting; no barometric damper
- d. Balanced Draft: Combines forced draft (FD fan pushes air in) and induced draft (ID fan pulls gases out) maintaining near zero pressure, optimizing control and minimizing infiltration.
 - Pressure: Near 0 in. WG
 - Optimized for large systems with tight control and minimal air leakage

Table 14. Furnace Drafts

	Draft Type	Pressure (in. WG)	Vent Rule	Blower (CFM)	Efficiency (AFUE)
	Natural Draft	-0.02 to -0.05	1 in ² / 4,000 Btu/h	None	70–80%
	Induced Draft	-0.05 to -0.1	1 in ² / 4,500 Btu/h	100–200	80–89%
	Forced Draft	+0.05 to +0.2	1 in ² / 5,000 Btu/h	50–150	85–95%
	Balanced Draft	~0 (Neutral)	Precisely sized	100–300 (FD + ID)	90%+

Notes





- Units: in. WG (water gauge) measures draft pressure; CFM reflects blower airflow.
- Natural draft needs tall chimneys: others use smaller vents (often PVC in condensing units).
- Natural draft relies on buoyancy; induced relies on exhaust pull; forced ensures intake push and tight venting; balanced optimizes pressure.
- Relevance: Match draft to efficiency and safety needs, natural for simplicity, balanced for precision.

Furnace Categories

Furnaces are classified into four categories (I–IV) based on vent static pressure (positive or non-positive) and flue gas temperature relative to the dewpoint. These categories guide venting design, safety, and efficiency.

- Category I includes non-condensing, natural or induced draft furnaces with non-positive pressure and hot flue gases $\geq 140^\circ\text{F}$ above dewpoint.
- Category II also has non-positive pressure condensing furnace with hot flue gases at $< 140^\circ\text{F}$; require corrosion-resistant vents.
- Category III involves forced draft, positive pressure systems with hot gases $\geq 140^\circ\text{F}$ above dewpoint.
- Category IV covers high-efficiency, condensing furnaces with positive pressure and cooler flue gases at $< 140^\circ\text{F}$; require sealed, corrosion-resistant venting.

Table 15. Furnace Categories





	Description	Rules of Thumb
	Furnace Category	Defines venting needs and materials: <ul style="list-style-type: none"> • Cat I: Standard venting (Natural/Fan-assisted) • Cat II: Corrosion-resistant • Cat III: Leak-tight (forced draft) • Cat IV: Leak-tight + Corrosion-resistant (Sealed combustion)
	Pressure Classification	<ul style="list-style-type: none"> • Cat I & II: Negative pressure, standard venting. • Cat III & IV: Positive pressure, sealed venting required to prevent leaks.
	Temperature Consideration	<ul style="list-style-type: none"> • Cat I & III: Flue temp $\geq 140^\circ\text{F}$, no condensation, corrosion resistance not essential. • Cat II & IV: Flue temp $< 140^\circ\text{F}$, corrosion-resistant materials needed.
	Safety/Efficiency	<ul style="list-style-type: none"> • Cat I & III: Ensures no spillage • Cat II & IV: No corrosion, e.g., Cat IV needs PVC venting, 90+% AFUE

Note: Fan-assisted allows higher capacity but demands careful sizing to avoid cooling flue gases excessively, whereas natural draft relies solely on buoyancy, offering simpler but less controlled performance.

Venting System

Vent system in a space heating furnace, safely removes combustion byproducts like carbon monoxide and water vapor to the outdoors. It is separate from the combustion air system, which supplies fresh air for fuel burning.

Table 16. Combustion Air vs. Venting System

	Details	Combustion Air	Venting System
	Function	Supplies oxygen for fuel combustion	Removes combustion byproducts
	Source	Indoors or direct from outside	Always directed outdoors
	Types	Indoor air, ducted outdoor air, sealed combustion	Natural draft, induced draft, power/direct vent
	Design Importance	Prevents incomplete combustion and CO formation	Prevents backdrafting and indoor pollution

Type of Vents

Vents differ in design and materials, affecting draft performance, corrosion resistance, and code compliance (e.g., unlined masonry prohibited). The three common venting types are:

- Direct Vent – a two-chambered venting system that pulls in outside air in one tube and expels flue gases separately through other tube.
- Power Vent – a two-chambered venting system that uses outside air for combustion like a direct vent system however it uses a fan to force airflow.
- Natural Vent (B-Vent) – a single chambered venting system that uses indoor air for combustion and relies on chimney draft for exhaust.

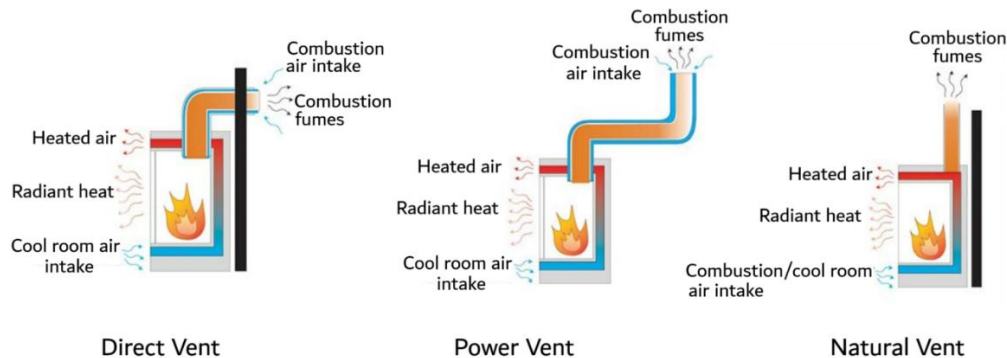

Figure 5. Type of Furnace Vents

Table 17. Direct Vent, Power Vent and Natural Vent





Description	Direct Vent	Sidewall Power Vent	Natural Vent (Type B)
Air Source	Outdoor (sealed system)	Indoor (typically)	Indoor/Outdoor (open system)
Exhaust Method	Sealed pipe (natural/fan-assisted)	Fan-driven (induced draft)	Chimney buoyancy
Pressure (inches of Water Gauge, in-WG)	Positive/Negative (varies)	Positive (+0.05 to +0.2 in. WG)	Negative (-0.02 to -0.05 in. WG)
Install Location	Sidewall or Roof	Sidewall	Roof (via chimney)
Safety/Efficiency	Highest (sealed, no indoor air risk)	High (fan ensures proper exhaust)	Moderate (backdraft risk possible)

Notes:

- Direct Vent: Sealed operation ensures safety, ideal for tight homes.
- Natural Vent: Passive mechanism suits simple, low-cost setups but risks backdrafts.
- Sidewall Power Vent: Fan-driven operation boosts reliability fits retrofits.

Each mechanism aligns with furnace needs (e.g., Direct for sealed Cat. IV, Natural for Cat. I), ensuring proper combustion and exhaust.

Table 18. Common Venting Configurations

	System	Description	Applies to
	Natural Draft	Uses chimney stack effect; warm gases rise naturally.	Category I Furnace
	Induced Draft	Fan draws flue gases out; allows smaller, horizontal vents.	Category I Furnace
	Direct Vent (Sealed Combustion)	Two-pipe system: one for intake, one for exhaust; sealed from indoor air.	Category IV Furnace
	Power Vent	Use a fan to push exhaust through vent pipe.	Category III Furnace
	Concentric Vent	Single pipe within a pipe, intake and exhaust in one assembly.	Category IV (compact design) Furnace

Furnace Category and Vent Category

Furnace categories and vent categories are not the same. Furnace categories determine what the appliance needs (pressure, temperature and draft), whereas vent categories provide how to meet

those needs (vent construction, types and materials) rather than pressure or temperature dynamics. Vent categories are defined by their physical properties and listing standards (e.g., UL).

- Type B: Double wall insulated vent; suitable for Category I non-condensing furnaces. Must terminate vertically above the roof.
- Type BW Vent: Specifically for gas wall furnaces.
- Type L: Heat- and corrosion-resistant; used for oil or gas appliances.
- Sealed combustion direct vent system where combustion air is drawn from outside and flue gases are exhausted outside, often through a sidewall. Two-pipe or concentric systems are used for Cat IV furnaces (PVC, CPVC, PP, or stainless-steel vent material).

HVAC designers select a furnace (e.g., Category I, 80% AFUE) and matches it with a compatible vent (e.g., Type B), ensuring system safety and efficiency.





Table 19. Venting System Types (Based on Furnace Category)

Furnace Category	Type	Vent Material	Typical Pressure & Temp	Condensing (Yes/No)
Category I	Natural draft or fan-assisted	Type B vent (metal)	Negative pressure, < 140°F	No
Category II	Low-temp condensing (rare in residential)	Corrosion-resistant	Negative pressure, < 140°F	Yes
Category III	Positive pressure, non-condensing	Stainless steel	Positive pressure, > 140°F	No
Category IV	Sealed combustion condensing	PVC, CPVC, or Polypropylene	Positive pressure, < 140°F	Yes

Vent Materials

Vents are made from a wide range of materials dependent on the furnace category. Each of these materials has its own set of benefits and drawbacks.

Table 20. Vent Materials

	Vent Material	Used For	Key Features
	Galvanized Steel	Type B (double wall): Cat. I furnace.	Handles high temps, not corrosion resistant. Avoid outdoors and not for condensing units.
	Aluminum	Type B inner: Cat. I/III furnaces.	Lightweight; not for condensing; needs dilution air.
	PVC, CPVC, or Polypropylene	Condensing furnaces (Cat. IV).	Lightweight, corrosion resistant. Only applications where the flue-gas temperature <180°F such as condensing furnaces.
	Stainless Steel	Type L or AL29-4C: Cat. II/IV power vented, high-temp furnaces.	Durable and corrosion resistant. Suits condensing units.

Notes:

- The vent must heat up quickly to establish a draft and prevent spillage.
- Large unlined masonry chimneys delay venting due to high heat absorption.
- Single-wall vents lose heat too fast, affecting efficiency.
- Double-wall vents are ideal chimney liners for gas appliances in new construction.

Vent configurations include single furnace, multiple furnaces (common/manifold), and multi-story venting.

Vent Size

General Principle: Vent must be large enough to carry away all flue products but not so large that it cools gases too quickly, affecting draft (for Cat I) or causing condensation in non-approved areas.



Common Sizes (Cat IV PVC): 2", 3", sometimes 4" diameter for residential. Follow the manufacturer's installation instructions precisely. Sizing depends on furnace input, vent length, number of elbows, and vent material.

Refer to NFPA 54 (National Fuel Gas Code) or local codes.

Single Vent System

This system uses a single pipe to exhaust flue gases from the furnace to the outside. Common for standalone units, it relies on natural draft (e.g., Type B vent) or fan assistance (induced/forced draft) to move the gases. Typically vertical; it uses a vent connector (horizontal/vertical sections) linking the furnace to the vent.



Table 21. Dos and Don'ts for Single Vent System

	Single Vent System	Rules of Thumb
	Do's	<ul style="list-style-type: none"> ✓ Size vent to match furnace Btu/h (e.g., 1 in²/4,000 Btu/h). ✓ Ensure 15-20 ft height for natural draft. ✓ Use double-wall Type B for insulation. ✓ Max 2 elbows; slope laterals ¼ in./ft up
	Don't	<ul style="list-style-type: none"> ✗ Undersize vent (smaller vent restricts airflow and may cause spillage). ✗ Use unlined masonry chimneys (can trap condensate increasing corrosion risk). ✗ Install excessive bends (>2 elbows reduce capacity 10% each).

Multi-Vent System with Manifold

A multi-vent system serves multiple furnaces, combining their flue gases into a common vent manifold, reducing the number of vent penetrations. It can vent appliances on one floor (manifold venting) or across multiple floors (multi-story venting), balancing draft for all units. Typically used in larger buildings with multiple heating units (furnace, water heater, etc.). Proper design ensures balanced airflow and prevents backdraft.

Table 22. Dos and Don'ts for Multi-Vent System

	Multi-Vent System	Rules of Thumb
	Do's	<ul style="list-style-type: none"> ✓ Min. Manifold Size: At least equal to largest connector; size up if multiple same-size connectors. ✓ Ensure connector rise (e.g., 1-2 ft min.) for each appliance. ✓ Stagger entries at different levels. ✓ Size common vent for total Btu/h. ✓ Slope manifold ¼ in./ft upward. ✓ Isolate from occupied spaces in multi-story setups.
	Don't	<ul style="list-style-type: none"> ✗ Connect connectors on the same horizontal plane (use staggered TEEs). ✗ Oversize manifold (cools gases, weakens draft). ✗ Exceed 10 ft manifold length or 50% vent height without derating.

Notes

- Single Vent: Simpler, more reliable for one unit; focus on sizing and height.
- Multi-Vent with Manifold: Cost-effective but complex; prioritize connector rise and manifold design to prevent dilution or backdraft.
- Refer to Vent Sizing Methodology for single furnace and common manifold multiple furnaces using NFPA 54 in Annexures 2 and 3.

Key Design Considerations

A properly designed venting system ensures safe removal of combustion gases, maintains indoor air quality, and supports furnace efficiency (ranging from 70% to 98% AFUE). Key components include vent pipes, terminations, and draft mechanisms such as natural draft (buoyancy), fan-assisted (induced or forced), and power venting systems.

Design Guidelines

- a. Vent Type Selection: Match the venting system to the furnace category (I to IV) to ensure compatibility with pressure and temperature conditions.
- b. Minimum Vent Area: For natural draft: 1 in² per 4,000 Btu/h input as a rule. For exact sizing, refer to NFPA 54 venting tables or local code requirements.
- c. Vent Height and Draft: Taller vents enhance natural draft performance.
- d. Typical heights: Natural draft systems: 15–20 ft minimum. Type B vents: Minimum 5 ft
- e. Approved Vent Materials: Use vent materials rated for the system's temperature and pressure. Type B (double-wall metal) for non-condensing furnaces and PVC/CPVC for condensing units with cooler exhaust gases.
- f. Vent Slope: Horizontal runs must slope upward 1/4 inch per foot toward the termination to support draft. Keep the lateral vent length to less than 75% of the total vertical height for optimal draft.
- g. Condensate Management: For condensing furnaces, slope vent piping downward toward the drain at 1/4 inch per foot. Install a drip leg or condensate trap to prevent water entry into the appliance.
- h. Avoid Overcomplex Layouts: Limit the number of 90° elbows (ideally no more than two); each elbow reduces vent capacity by ~10%.

Initiating the Fire

In space heating furnaces, fire is initiated to begin the combustion process that generates heat. The ignition method varies based on the type of fuel used, natural gas or fuel oil. Each system follows key design and safety benchmarks to maintain performance and code compliance.



Fuel Oil Combustion

Oil is pressurized, atomized into a fine mist, and mixed with air (~14.4:1) for ignition via spark or glow coil. Excess air (10–50%) ensures clean burn. Firing rate is set by pump pressure, nozzle size, and orifice. Type L flue (570°F) and a barometric damper maintain draft at –0.02 to –0.05 in. W.G.

Natural Gas Combustion

Gas flows to the burner when the valve opens and ignites via pilot, spark, or hot surface igniter. Combustion uses a ~10:1 air-fuel mix with 10–30% excess air. A draft hood manages airflow; safety is maintained by sensors and controls.











Table 23. Initiating Combustion for Gas and Oil Furnaces

	Fuel Type	Ignition Method: Rules of Thumb
	Natural Gas	HSI or DSI is a recommended option. <ul style="list-style-type: none"> • Standing Pilot (Obsolete for new furnaces): Continuously burning pilot light. • Intermittent Pilot: Pilot light is lit by an electronic spark only when there's a call for heat. More efficient than standing pilot. • Hot Surface Igniter (HSI): Most common in modern furnaces. A silicon carbide or nitride element heats to a high temperature to ignite the gas. Uses less fuel than pilot systems. • Direct Spark Ignition (DSI): Uses a high-voltage spark directly at the main burners to ignite gas.
	Fuel Oil	High-voltage spark across electrodes/glow coil ignites atomized oil. <ul style="list-style-type: none"> • Preheat oil to 100–140°F. • Electrode gap: 1/8"–3/16". • Ensure clean atomization
	Safety Controls	Gas: Flame sensor, shut-off valve; Oil: Cad cell, pump cutoff; test annually.

Notes

- Relevance: Ensures efficiency (80-98% AFUE gas, 80-87% oil), safety (no CO/soot), and compliance with codes.
- Adjustments: Tune via flue gas analysis (O₂/CO) for optimal combustion.

Table 24. Safety in Space Heating Furnaces

	Safety	Rules of Thumb
	Hazardous Atmospheres	Avoid using furnaces near flammable vapors, dust, or chlorinated/hydrocarbons.
	Gas System Leak Test	Test all gas lines for leaks at $\geq \frac{1}{2}$ PSIG before operation.
	Heater Location (Gravity Vent)	Install on roof/slab, 20 ft from walls/parapets to avoid draft interference.
	Proper Venting	Follow manual/code for flue setup; improper venting risks injury or damage.
	Flammable Storage	Don't store gasoline or flammable liquids near the furnace.
	Flue Duct Joints	Seal all joints tight to prevent air leaks and combustion issues.
	Thermostat Rating	Ensure VA rating matches connected load (e.g., 24V, $\geq 5VA$).
	Gas Supply Pressure	Max $\frac{1}{2}$ lb. (14 in. WG); use regulator if inlet pressure exceeds this.
	Pressure Testing Precaution	Close shutoff valve during tests above $\frac{1}{2}$ PSIG to protect furnace components.
	Pilot Voltage Safety	Avoid contact with spark wire/electrode, high voltage hazard.











Notes

- Safety Focus: Prevents fire, CO poisoning, and equipment damage.
- Compliance: Follow NFPA 54, local codes, and manuals for all practices.

High Efficiency Furnaces

High-efficiency furnaces use two heat exchangers to remove as much heat as possible from the combustion gases before venting them to the outside air. This process generates a substantial amount of condensation. These furnaces are also called sealed combustion furnaces because these draw outdoor air straight into the furnace for fuel combustion and expel it through the flue.

Table 25. High-Efficiency Furnaces for Space Heating

	Parameters	Rules of Thumb
	Efficiency (AFUE)	90–98%; aim for 95%+ in cold climates for best fuel savings.
	Vent Material	PVC/CPVC; corrosion-resistant, 0" clearance; max flue temp <180°F.
	Vent Sizing	1 in ² /5,000 Btu/hr.; e.g., 4 in. for 80k–120k Btu/h; must be leak-tight.
	Condensate Mgmt.	Expect 0.5–1 gal/day; slope vent to drain; follow manufacturer instructions.
	Air Supply	Use sealed/direct vent; bring outdoor air via separate intake pipe.
	Install Location	Install in conditioned space; avoid areas prone to freezing.
	Sizing	Size to peak load (30–60 Btu/h/ft ²); add 10–15% buffer, avoid oversizing.
	Draft Type	Forced draft (+0.05 to +0.2 in. WG); fan-driven, prevents backdrafts.
	Maintenance	Check heat exchanger, vent, and drain annually; clean system yearly.
	Energy Savings	20–30% less fuel use vs. 80% AFUE; higher upfront, lower lifetime cost.

Notes

- Relevance: Suits cold climates, tight homes; ensures safety (no CO risk) and efficiency.
- Codes: Follow NFPA 54 for venting, local codes for installation.

Table 26. Heating Furnaces , Minimum Efficiency Requirements, ASHRAE 90.1, Table 6.8.1-5

Equipment Type	Size Category (Input)	Subcategory or Rating Condition	Minimum Efficiency	Test Procedure
Warm-air furnace, gas fired	<225,000 Btu/h	Maximum capacity	78% AFUE or 80% Et	DOE 10 CFR Part 430 or Section 2.39, Thermal Efficiency, ANSI Z21.47
	≥225,000 Btu/h		80% Et	Section 2.39, Thermal Efficiency, ANSI Z21.47
Warm-air furnace, oil fired	<225,000 Btu/h	Maximum capacity	78% AFUE or 80% Et	DOE 10 CFR Part 430 or Section 42, Combustion, UL 727
	≥225,000 Btu/h		81% Et	Section 42, Combustion, UL 727
Warm-air duct furnaces, gas fired	All capacities	Maximum capacity	80% Ec	Section 2.10, Efficiency, ANSI Z83.8
Warm-air unit heaters, gas fired	All capacities	Maximum capacity	80% Ec	Section 2.10, Efficiency, ANSI Z83.8
Warm-air unit heaters, oil fired	All capacities	Maximum capacity	80% Ec	Section 40, Combustion, UL 731

Acronyms:

- AFUE Annual Fuel Utilization Efficiency – A measure of seasonal efficiency for heating equipment, accounting for start-up, cool-down, and cycling losses.
- Et: Thermal Efficiency – The ratio of heat output to heat input during steady-state operation.
- Ec: Combustion Efficiency – The ratio of energy transferred to the airstream to the energy in the fuel consumed.
- DOE 10 CFR Part 430: U.S. Department of Energy regulation for consumer products, covering energy conservation standards and test procedures.
- ANSI: American National Standards Institute standard
- UL: Underwriters Laboratories standard

Codes and Standards

Direct gas-fired heater design must align with multiple codes and standards: ASHRAE 90.1 governs energy efficiency, while NFPA 54, the International Fuel Gas Code (IFGC), and ANSI standards Z83.4 and Z83.18 define critical requirements for combustion air, emissions, safety controls, and venting.

Table 27. NFPA 54 / IFGC Mandatory Requirements















	Requirements	Mandate
	Listing & Certification	Appliances must be listed/labeled by an approved agency (e.g., UL, CSA) for the fuel type (natural gas or LPG) used.
	Installation Instructions	Must comply with manufacturer’s installation instructions.
	Combustion Air Supply	Sufficient combustion air from indoor or outdoor sources. May be supplied from indoors (large volume spaces) or from outdoors via ducts or vents. Combustion air openings must not be obstructed.
	Location Restrictions	Furnaces must not be installed in: Sleeping rooms or bathrooms unless installed in a sealed enclosure with outside combustion air (NFPA 54 §10.1.2).
	Clearances to Combustibles	Must meet manufacturers or code-specified clearances.
	Venting	The type of venting system must match furnace category (e.g., Category I, II, III, IV), sized per code.
	Safety Controls	Furnaces must have: Automatic ignition systems, Safety shut-off valves, Limit switches to prevent overheating, Electrical wiring compliant with NFPA 70 (NEC).
	Gas Piping	Gas supply must meet sizing, material, and pressure test requirements (NFPA 54 Chapter 5 / IFGC Chapter 4). Shutoff valves must be installed within 6 feet of the appliance. Sediment traps (drip legs) typically required upstream appliance controls.
	Testing & Inspection	Mandatory: must pass leak and operational tests before use.
	Service & Access	Must allow access for maintenance and code inspections.

Table 28. ANSI Z83.4 & Z83.18 - Emissions Requirements

	Emission	Benchmark Value/Rules of Thumb
	ANSI Z83.4 non-recirculating direct gas-fired industrial air heaters (100% outside air)	Must limit CO ≤ 5 ppm, NO ₂ ≤ 0.5 ppm, CO ₂ ≤ 4,000 ppm. Requires ignition, air, and flame controls.
	ANSI Z83.18 recirculating direct gas-fired industrial air heaters (using return air).	Allows higher limits based on recirculated air percentage to ensure safety; CO ≤ 25 ppm, NO ₂ ≤ 3 ppm, CO ₂ ≤ 5,000 ppm.
	Combustion Efficiency	≥ 78% (typical for non-condensing), ≥ 90% (for condensing)
	Spillage	Must not spill combustion gases after a set period (usually 5 min)
	Flame Failure Response	Automatic shutdown within 0.8–3 seconds after loss of flame

Furnace Room Sizing

A furnace room must provide safe access, adequate combustion air, and proper space for installation, service, and ventilation. Correct sizing ensures efficient operation, easy maintenance, and code compliance.

Key Design Considerations

- Capacity & Layout: Room size depends on furnace input (Btu/h), number of units, duct take-offs, and controls.
- Service Clearances: Always follow manufacturer instructions. Refer to standard practices below:
 - Front: 36 in. minimum for servicing
 - Sides: 24 in. where access is needed
 - Top: 12–18 in. for duct and component access
- Combustion Air & Ventilation: Provide dedicated combustion air per equipment input. Include ventilation openings or fans to remove excess heat.
- Venting / Flue: Combustion gases must vent safely using Type B or power-vented systems. Condensing furnaces need condensate drainage.
- Noise & Vibration: Use flexible connections and isolation where required.
- Safety & Fire Separation: Maintain code-required fire ratings and non-combustible clearances.

Table 29. Typical Furnace Footprint by Capacity and Type

Furnace Capacity (Input Btu/h)	Typical Application	Approx. Dimensions (W × D × H)	Floor Footprint (ft ²)	Notes
60,000–100,000	Small residential	17–21" × 28–32" × 34–40"	3–4 ft ²	Common gas furnaces for homes up to ~2,000 ft ² .
100,000–150,000	Large residential / small commercial	21–24" × 30–36" × 40–48"	4–6 ft ²	May include higher blower capacity for long duct runs.
150,000–250,000	Light commercial / small office	24–30" × 36–40" × 48–54"	6–8 ft ²	Often multiple units are installed for zoning or redundancy.
250,000–400,000	Medium commercial / institutional	30–36" × 40–48" × 54–60"	8–12 ft ²	Usually floor-mounted; may be packaged with cooling coils.
400,000–660,000+	Large commercial / industrial	36–48" × 48–60" × 60–70"	12–20 ft ²	Typically packaged rooftop or mechanical room units.

Table 30. Service Clearances for Furnaces

Parameter	Guidelines
Front Clearance (Service)	36 in. minimum
Side Clearance	24 in. where access needed
Top Clearance	12–18 in. for duct/vent space
Unit Spacing	12–24 in. between cabinets
Combustion Air Opening	Sized per appliance input and local code
Working Space (Controls)	30 in. × 30 in. minimum
Future Expansion	Plan 10–25% extra floor space
Typical Room Size	50–200 ft ² for small commercial setups

Notes: When designing furnace rooms:

- Use manufacturer dimensions for exact models.
- Verify egress, combustion air, and venting per local building and fire codes.
- Allow front clearance (36 in) and side clearance (24 in) for maintenance.
- For space planning, assume 6–20 ft² footprint per furnace, depending on capacity.

Example: Furnace Room Sizing

Floor Area: 20,000 ft²

Heating Load: 30 Btu/ft²

Total Load: $20,000 \times 30 = 600,000$ Btu/h

System Options: $2 \times 300,000$ Btu/h furnaces (recommended for redundancy)

Typical Unit Footprint: ~36" x 48" (~3 ft x 4 ft)

Room Area Estimate: ~9 ft x 12 ft (including 36" front and 24" side clearances)

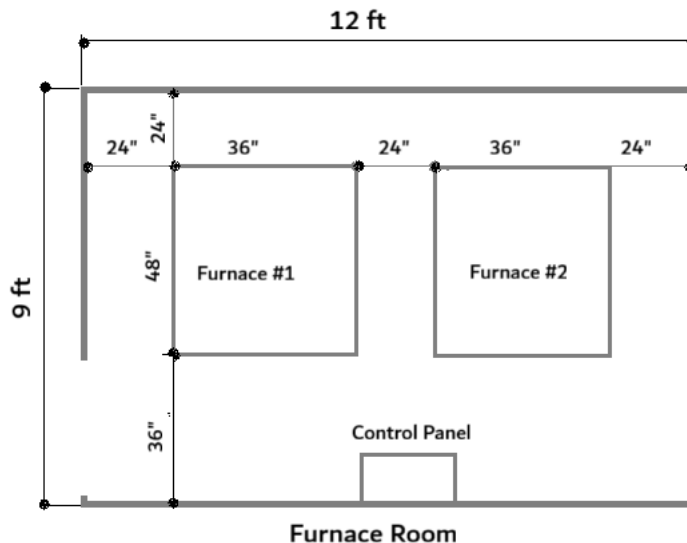

Total Room: $9 \times 12 = 108 \text{ ft}^2$

As a rule of thumb, consider $\sim 50\text{--}60 \text{ ft}^2$ room space per unit including clearance and circulation area.

Egress & Code Requirements

Plan furnace rooms for safe access, service space, and ventilation.

- Rooms over 500 ft^2 or containing fuel-fired equipment exceeding 400,000 Btu/h input require two exit doors (per IBC 1006.2.2.1).
- Exit doors must be separated by at least half the room's diagonal for safety.
- Maintain clear access paths for exits and control panels.

Summarizing

The right furnace choice depends on a combination of factors, including:

- Furnace Sizing by Heat Load: Approximate based on Climate Zones.
 - US Climate zone (1, 2 and 3): 5-25 Btu/h/sq. ft.
 - US Climate zone (4 to 6): 25-60 Btu/h/sq. ft.
 - US Climate zone (7 & 8): 50-100+ Btu/h/sq. ft.

Use lower values for well insulated buildings and higher for old construction poorly insulated buildings.

- b. Fuel Type: Natural gas is most common in urban residential areas; LPG (propane) is used where piped gas is unavailable; electric furnaces suit off-grid or smaller spaces; oil is commonly used in remote rural/industrial areas.
- c. Furnace Efficiency (AFUE): Ranges from 80% to 98%. Std: 80-85% (min 80% per DOE 2023). High: 90-98%+ (condensing) especially beneficial in colder climates.
- d. Capacity Requirements: Determined by heat loss calculations (Manual J). Climate zone and building insulation significantly impact the required output.
- e. Supply Air Temp: 100-140°F (target 120°F for comfort)
- f. Temperature Rise (ΔT): 30-60°F (gas/oil), 20-40°F (electric). Target 40-50°F. Low ΔT : Cool drafts. High ΔT : Overheating risk.
- g. Airflow Rate: 130-310 CFM per 10,000 Btu/h (based on ΔT). $CFM = 10,000 \div (1.08 \times \Delta T)$.
- h. Furnace Categories: Category I: Natural draft, non-positive pressure flue gas; Category II: Condensing, negative pressure; Category III: Non-condensing, positive pressure; Category IV: Condensing, positive pressure.
- i. Furnace Draft and Vents: Natural Draft, Induced Draft, Forced Draft, Sealed Combustion (Direct Vent). Vent Type: Type B Vent, Direct Vent (PVC/CPVC/PP/Stainless Steel for Cat IV). Vent Size: Use 2"-4" for Cat IV PVC; size per mfr. instructions and NFPA 54.
- j. Combustion Air: Traditional: Indoor air needs openings. Sealed: Outdoor air, safer, efficient. Rule: $\sim 50 \text{ ft}^3$ per 1,000 Btu/h. Excess Air: 10-20% for optimum efficiency. Oxygen in flue gas: 2-5% ideal; $>6\%$ signals too much air.
- k. Space Classification: Confined Space needs extra ventilation openings, Unconfined Space (no extra air needed). Confined if $\text{Room Vol (ft}^3) < (\text{Total Btu/h} \div 20)$.
- l. Installation and Space Constraints: Choose between up flow, downflow, or horizontal configurations depending on layout limitations.
- m. Controls: Choose single stage for consistent climates. Two-stage for variable climates and modulating for precise control.
- n. Ignition System: Hot Surface Ignition, HSI (common), Direct Spark Ignition, DSI (durable), Intermittent Pilot (older) and Standing Pilot (obsolete).
- o. Safety: Include CO detectors; ensure sealed combustion, proper venting and combustion air, install limit/rollout/pressure switches, flame sensor. Follow NFPA 720, regular maintenance.
- p. Climate Suitability: Gas: Cold ($>4,000$ HDD). Electric: Mild ($<2,000$ HDD). High AFUE for cold climates, hybrid for moderate climates.
- q. Codes & Standards: Follow NFPA 54, IMC/UMC, IECC, ASHRAE 90.1/62.1, and local codes.
- r. Capital Cost: \$2,000-\$10,000+ (depending on efficiency, features). Approx. Order (Low to High): Electric $<$ Gas 80% $<$ Gas 90%+ $<$ Oil. Higher AFUE/features = higher cost.

- s. Operating Cost: Gas: Often cheapest. Electric: Highest. Higher AFUE lowers fuel use. Calculate: $(\text{Load} \div (\text{AFUE} \times \text{Fuel Btu})) \times \text{Fuel Cost} + \text{Electric Cost}$.
- t. Life Expectancy: Gas: 15–20 yrs; Oil: 15–25; Electric: 20–30.
- u. Zoning Capability: Standard: Single zone. Zoning: Use dampers, two-stage/modulating furnaces, variable-speed blowers for multi-zone comfort.
- v. Common Pitfalls: Avoid oversizing, poor ducting, vent errors, skipping commissioning/maintenance.
- w. Other Factors: Brand reliability, safety features, noise levels, ease of maintenance, and budget all play a role in decision-making.

Proper furnace sizing is crucial. While Manual J provides the most accurate method, common guidelines can help estimate:

- 30 Btu/h/ft² for well-insulated homes in mild climates
- 60+ Btu/h/ft² for colder regions
- Add 10–20% buffer for cold snaps
- Derate gas furnace output by 4% per 1,000 ft elevation.
- Oversizing: Oversizing by more than 20% of your heating requirement will result in short cycling, which wastes 5-15% fuel. Add 10-15% buffer to peak load.
- Under sizing: Constant run cuts lifespan by 20-30%. If you select a furnace that falls more than 10% short of your heating needs, go up the size. Oversizing is preferable to under sizing.

CHAPTER 2: HYDRONIC HEATING SYSTEMS

Hydronic systems, sometimes referred to as “water-based” systems, use steam or water to heat air. These systems typically operate on the principles of convection and radiation, providing quieter and uniform heating. Thanks to water’s excellent thermal properties, these systems offer energy efficiency and application in large and relatively tight spaces.

A hydronic system is typically made up of the following components:

- a. Heat Source: Usually, a boiler for heating or a chiller for cooling.
- b. Distribution Network: A network of pipes that circulate water or other heat-conducting fluids.
- c. Heat Exchange Units: Components like radiators, convectors, fan coil units, or radiant floor systems, where heat is transferred to or from the room air.

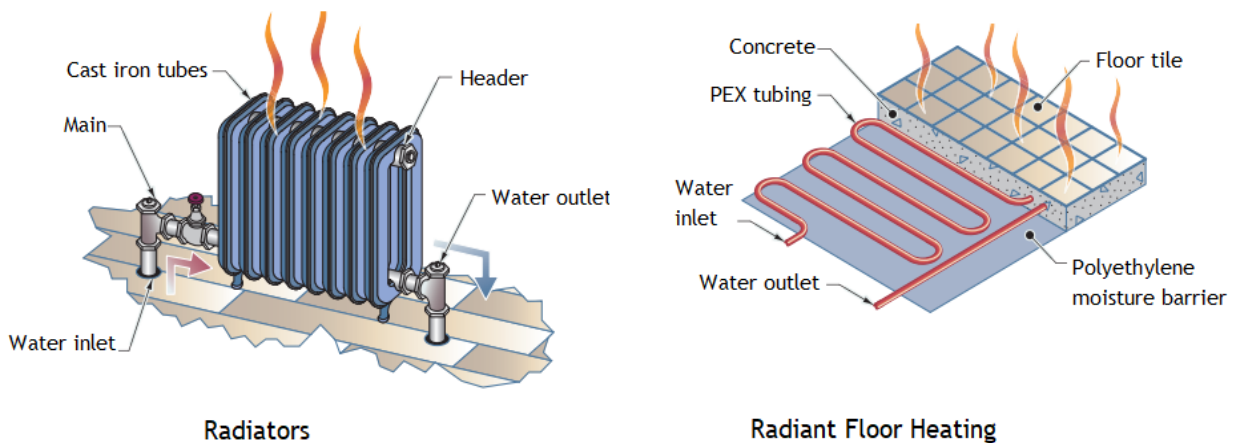

Figure 6. Hydronic Heat Emitters

Working of Hydronic Heating System

A hydronic heating system works by circulating hot water from a boiler through a network of pipes to heat emitters such as radiators, baseboards, or underfloor coils. The water delivers heat to space, then returns to the boiler for reheating. A control system regulates the output to maintain steady indoor comfort.

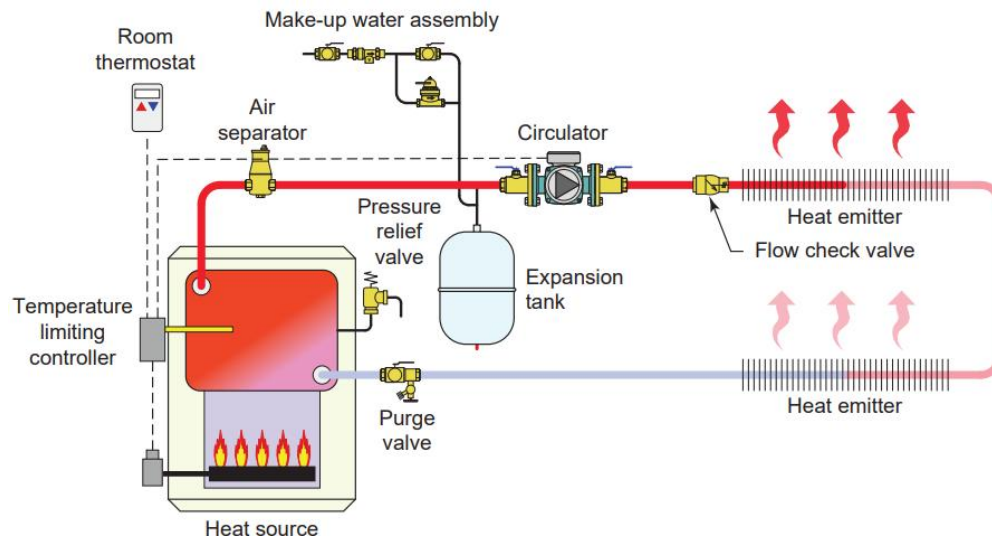

Figure 7. Hydronic Heating Schematic

System Components:

- Hot Water Boiler: Heats water to 160°F - 180°F
- Pumps: Circulate hot water through pipes
- Radiators/Baseboards: Transfer heat to space
- Expansion Tank: Regulates system pressure











Major components, such as the heat source and heat emitters, have temperature and flow requirements that must be properly matched, if the system is to function efficiently. Heat emitters can be classified as radiant or convective although most combine the two modes of heat transfer. Proper insulation and zoning improve efficiency.





Water vs Air as a Heating Medium

Water has a higher heat-carrying capacity than air, meaning it can transport more energy with less volume, reducing the energy required for heating or cooling. Heating one gallon of water by 20°F (from 170°F to 190°F) stores 167 BTUs (8.33 lbs. × 20°F × 1), while air, with a heat capacity of 0.018 BTU/ft³, requires 464 cubic feet to hold the same heat ($Q \times 0.018 \times 20 = 167$, $Q = 464 \text{ ft}^3$).

The heat quantities are predominantly expressed within a 1-hour time frame; therefore, the heating loads are always referenced as Btu/h.

Table 31. Hydronic Heating (Boiler) vs. Forced Air Heating (Furnace)

	Factors	Hydronic Heating (Boiler + Radiators/Radiant)	Forced Air Heating (Furnace + Ducts)
	Heat Requirements (BTU needs)	25–35 Btu/ft ² for radiant floors; lower per square foot due to even heat distribution and thermal mass.	30–60 Btu/ft ² ; varies with insulation, layout, and duct efficiency. Higher needs due to air heat loss and less uniformity.
	Operating Principle	Heats water, circulates to radiators, baseboards, or radiant floor tubing. Heat is transferred from water to room surfaces and air.	Burns fuel to heat air directly, which is then distributed through ducts to occupied spaces. Heat is delivered via warm airflow.
	Supply Water Temp. (Boilers)/ Supply Air Temp. (Furnace)	140-180°F for standard boilers. 120-160°F for high efficiency condensing boilers.	100-140°F (often around 120°F). Closer to 100°F for high-efficiency furnaces.
	Return Water temp. (Boilers)/ Return Air Temp. (Furnace)	100-120°F, depending on the system and load.	65-75°F, reflecting typical indoor ambient temperatures.
	Temperature difference or Temperature rise (ΔT)	20-40°F, depending on the water flow rate and terminal emitter (radiator/baseboard) design.	20-60°F (typically around 40°F) depending on airflow rate and heat load.
	Efficiency (AFUE)	80-85% standard and up to 98% for condensing boilers.	78-96% (High-efficiency modern furnaces)
	Heat Distribution	Consistent radiant heat (via water), minimizing temperature fluctuations	Convective heat (via air), can be drafty and uneven.
	Distribution Losses	Minimal (small bore insulated pipes)	20–30% (large ducts and air leakages)
	Zoning Flexibility	Easy, room-level control	Complex, needs dampers
	Comfort and Air Quality	Clean, no air movement.	Airflow spreads dust/allergens.

	Noise	Quiet	Noisy fans and airflow noise (30-60 dB)
	Installation Cost	Higher (\$8–15/ft ²)	Lower (\$5–10/ft ²)
	Operating Cost	Lower in efficient buildings	Higher due to duct losses
	Lifespan	20–30 years	15–20 years

Key Takeaways:

Hydronic systems excel in comfort and quietness. Forced air systems are often cheaper to install and heat quickly. Hydronic systems can transport heat over long distances using insulated pipelines, making them ideal for large multistory or campus-style buildings, unlike forced air, which is limited by ductwork length.

Design Steps for Hot Water Heating System









Designing a hydronic hot water heating system involves several key steps to ensure efficient and comfortable heating. Here's a breakdown of the design process in 8 Steps.

1. Determine heating load
2. Size the heat source – Boiler
3. Determine the Type of Heating Units/Emitters
4. Determine Pipe Distribution Layout and Sizes
5. Select Circulation Pump
6. Select Piping Auxiliaries (expansion tank & air separators)
7. Evaluate Control System
8. Verify System Efficiency and Safety

1.1.8 Determine Heating Load

Heating system design, whether hydronic or otherwise, begins with calculating the building's heating load, the amount of heat loss, and the energy required hourly to maintain a comfortable temperature. Typically, it ranges between 20 to 60 Btu/h per square foot of floor area and depends on factors like its geographic location and climate, building size, the number of windows and doors, the quality and amount of insulation in its walls and ceilings, ventilation and air infiltration. Use industry standard heat loss calculation methods such as Manual J or ASHRAE standards.

Table 32. Heat Loss Estimation based on Climate Zones

	Climate Zone	General Climate Description	Typical Heat Loss Range (Btu/h·ft ²)	Heat Loss Considerations
	Zone 1 (Miami, FL)	Hot, Humid	5-10 Btu/h·ft ²	Minimal heating needed; Cooling dominated, focus on minimizing solar heat gain.
	Zone 2 (Houston, TX)	Warm, Humid	10-15 Btu/h·ft ²	Mild winters, low heating demand.
	Zone 3 (Atlanta, GA)	Hot-Dry/Mixed-Humid	15-25 Btu/h·ft ²	Moderate heating; wide temperature swings in dry climates.
	Zone 4 (Washington, D.C.)	Moderate Climate	20-35 Btu/h·ft ²	Moderate heating; varying humidity levels.
	Zone 5 (Chicago, IL)	Cool Climate	30-50 Btu/h·ft ²	Significant heating load; insulation is crucial.
	Zone 6 (Minneapolis, MN)	Cold Climate	40-60 Btu/h·ft ²	High heating load; very cold winters.
	Zone 7 (Denver, CO)	Very Cold	50-70 Btu/h·ft ²	Very high heating load; extremely cold.
	Zone 8 (Anchorage, AK)	Subarctic/Arctic	70-100+ Btu/h·ft ²	Extreme heating load; severe winters.

As an example, if you have a 2,000-square-foot house in a moderate climate (climate zone 4), you need a boiler that can produce approximately 70,000 Btu/h at 35 Btu/h.ft².

Note: Rules of thumb for heat load are for validation only. Since every building is unique, always perform detailed heat loss calculations, including losses through walls, windows, doors, ceilings, floors, and from ventilation or infiltration, using recognized industry methods or software tools.

Size the Heat Source - Boiler

Size the boiler based on the building's total heat loss plus a 10–20% safety margin for cold snaps, inefficiencies or unforeseen heat losses. Choose the boiler type (condensing or non-condensing, fire-tube or water-tube), fuel source (natural gas, propane, oil, electricity), efficiency (AFUE), and zoning needs (e.g., one modulating unit or multiple boilers).

Determine Type of Heating Units/Emitters

Heat emitters such as radiators, baseboards, radiant floors, or fan coils transfer heat from hot water to the room. Start by sketching the building layout, marking room locations, emitter types, and their placement. Common emitter types include:

- Radiant floors – for even, comfortable heat.
- Baseboards – ideal along exterior walls with quick response.
- Radiant panels – efficient wall or ceiling-mounted options.
- Fan coils – offer forced-air heating and cooling capabilities.

Size emitters surface area based on each room's heat load (Btu/h). Manufacturers provide output ratings for emitters at specific water temperatures (e.g., 180°F or 140°F). Match emitter output to room needs.

Determine Pipe Distribution Layout and Sizes

Decide how hot water will circulate from the boiler to emitters and back. Common layouts include:

- Series Loop – water flows through all units in sequence, cooling as it moves.
- One-Pipe – a single main pipe supplies all units with branch connections.
- Two-Pipe Direct Return – closest unit gets the hottest water, shortest return path.
- Two-Pipe Reverse Return – ensures balanced flow with all elements have similar return path lengths.
- Zoned System – separate loops controlled by valves and thermostats, allowing for individual zone temperature control.
- Primary-Secondary – primary boiler loop feeds secondary zone loops for better control.

Pipe Sizing

Select pipe sizes based on flow rate (GPM) and head loss. Pipe size affects flow rate and heat delivery, too small causes noise or insufficient heat, too large wastes material. Choose appropriate pipe sizes and materials (PEX, copper, steel). Include expansion tanks, pumps, and valves (e.g., zone valves for multi-zone systems).

Select Circulator Pump

Select a circulation pump with sufficient flow rate (GPM) and head pressure to overcome piping resistance. Flow rate is calculated based on the boiler output and temperature differential (ΔT). ΔT is typically 20°F for standard systems and 30-40°F for high-efficiency systems. As a rule of thumb, use 1 GPM per 10,000 Btu/hr. of heating load for a 20°F temperature rise, i.e., $GPM = BTU/h \div 10,000$ for a 20°F temperature rise.

Select Piping Auxiliaries (Expansion Tank and Air Elimination)

Select an expansion tank at approximately 10% of the total system water volume to accommodate thermal expansion. Install air elimination devices like an air separator (typically near the boiler outlet) and automatic air vents at high points to remove dissolved and trapped air. These components support quiet, efficient, and durable hydronic system performance.

Thermal Zoning

Zoning allows independent temperature control in different areas of a building, enhancing comfort and energy efficiency. Each zone typically uses its own thermostat and zone valve (or circulator) and may have separate heat exchangers based on usage needs.













Key Zoning Elements:

- Thermostats per zone to control local temperature.
- Zone valves or circulator pumps to direct hot water flow.
- Boiler controls to modulate heat output based on total demand.
- Outdoor reset control to automatically adjust water temperature in response to outside weather, improving system efficiency.

Verify System Efficiency and Safety

Ensure the design minimizes energy loss and meets codes (e.g., pressure relief valves, backflow preventers). Insulate pipes and check for balanced flow. Review calculations, insulate exposed pipes, and test flow rates after installation. Adjust as needed.

Table 33. Designing Hot Water Heating System

	Parameters	Rules of Thumb
	Heat Load	Climate Zones: <ul style="list-style-type: none"> • Zones 1–3: 5–25 Btu/h/ft² • Zones 4–6: 20–60 Btu/h/ft² • Zones 7–8: 50–100+ Btu/h/ft² Use lower values for well-insulated buildings.
	Boiler Sizing	Add 10–20% above calculated heat load as safety buffer.
	Water Supply Temp.	120–140°F (radiant floors), 180°F (baseboards/radiators).
	ΔT (Temp. Difference)	20°F standard, 30–40°F for high-efficiency systems.
	Pipe Sizing (Copper)	Size piping based on the flowrate (GPM depending on boiler output), pipe velocity and pressure drop. <ul style="list-style-type: none"> • ¾" pipe for up to 40,000 Btu/hr. • 1" pipe for up to 80,000 Btu/hr. Keep the velocity <4 ft/s; <4 ft/100 ft pressure drop.
	Pump Flowrate	1 GPM per 10,000 Btu/h (20°F ΔT).
	Pump Head	6–10 ft per 100 ft of pipe.
	Emitters Output	Various types of emitters are typically used: <ul style="list-style-type: none"> • Radiator: 500-1,000 Btu/h per section • Convector: 150-200 Btu/h per ft length • Fan coil unit: 200-500 Btu/h per unit • Radiant panel: 20-40 Btu/h per ft² • Radiant floor: 10-20 Btu/h per ft²
	Radiant Floor Spacing	6–12 inches (closer for higher output).
	System Pressure	10–30 psi.
	Expansion Tank	Higher of following apply for conceptual design: <ul style="list-style-type: none"> • 10% of system water volume • 1 gal per 50,000 Btu/h • 1 gal per 10-gal water
	Air Separator Size	1–5 gal per 100,000 Btu/hr.
	Air Vent Placement	At system high points.

Steam Boiler vs. Hot Water Boiler

Steam boilers and hot water boilers are both used for space heating, but they differ in their operation, design, and application.

- a. Steam boilers heat water until it turns into steam. This steam travels upward through a network of pipes to heat emitters such as radiators or convectors, releasing heat as it condenses back into water and returns to the boiler to be reheated and reused. Less efficient than modern hydronic systems due to higher operating temperatures and energy losses from steam piping. Typically, used in older buildings and some industrial applications.
- b. Hot water boilers, on the other hand, heat water (without turning it into steam) and circulate it through pipes to radiators or underfloor systems, transferring heat directly to the space before returning to the boiler for reheating.

Hydronic hot water system offers more precise temperature control, quieter operation, and improved energy efficiency compared to steam systems. It is the most common choice for residential and light commercial heating applications today.

Table 34. Steam Boiler vs. Hot Water Boiler

	Feature	Steam Boiler	Hot Water Boiler
	Operating Fluid	Steam (vaporized water)	Hot water (liquid)
	Operating Temp.	≥212°F	140°F–180°F (typical)
	Operating Pressure	0–15 psi	12–30 psi (closed-loop)
	Heat Transfer	Latent heat	Sensible heat
	Delivery	Radiators only	Radiators, baseboards, in-floor tubing
	Efficiency	Lower (phase change losses)	Higher (direct transfer)
	System Design	Complex (traps, condensate return, pressure controls)	Simpler (pumps, valves)
	Heat-Up Time	Fast	Slower, more consistent
	Boiler Sizing	60–80 Btu/ft ²	50–60 Btu/ft ²
	Flow Rate	N/A (natural rise of steam)	1 GPM per 10,000 Btu/h, (20°F ΔT).
	Pump Requirement	No pump needed	Requires pump
	Condensate Handling	Return system required	Not required
	Piping	Larger, steam-rated	Smaller, lower pressure rated
	Emitters	Cast iron/steel radiators (1 per 100–150 ft ²)	Radiators/baseboards/radiant (1 per 100–150 ft ²)
	Install Cost	Higher (complex system)	Lower
	Zoning	Difficult	Easy with multiple loops
	Maintenance	Higher (traps, water hammer, corrosion)	Lower (fewer components)
	Best Use	Large/commercial/industrial high heat demand	Residential/commercial/moderate heat demand

Notes: Steam systems rely on natural pressure differences, requiring careful pipe sloping (1/4 inch per 10 feet), while hot water systems need pumps and expansion tanks. Hot water systems are generally preferred for their energy efficiency and quieter operation.







In this course, we'll talk about hot water boilers and heaters.

Hot water Boiler vs. Hot water Heater

A hot water boiler and a hot water heater are terms often used interchangeably in casual conversation, but they serve distinct purposes in a space heating system.

- a. Hot Water Boiler: Heats water to 140-180°F and circulates it in a closed loop for space heating. Some boilers also provide domestic hot water (combo units).
- b. Hot Water Heater: Heats water to 120–140°F for domestic use (e.g., showers, sinks, dishwashers, washing machines and other appliances) and operates in an open-loop system. It does not provide space heating and requires a separate heating system like a boiler, furnace, or heat pump.

Table 35. Hot Water Boiler vs. Hot Water Heater

	Parameters	Hot Water Boiler	Hot Water Heater
	Primary Use	Space heating (radiators, floors, baseboards)	Domestic hot water (sinks, showers)
	Operating Temp.	140°F–180°F (up to 212°F for steam)	120°F–140°F (safety limit)
	System Type	Closed-loop hydronic system	Open system (water is consumed)
	Efficiency (AFUE)	85%–95% (modern models)	80%–98% (tankless higher)
	Sizing	40–60 Btu/h/ft ² (moderate); 70–100+ Btu/h/ft ² (cold climates)	40–50-gal tank for 4-person home
	Output Capacity	50,000–200,000 Btu/h (residential)	30,000–50,000 Btu/h (typical unit)

Hot Water System Design Configurations

Hydronic hot water system uses heated water to deliver space heating. The system design is typically divided into two parts, air side and water side, each responsible for different Parameters of heat distribution and control.

Air Side Design Configurations

The air side includes components that transfer heat from the water to the air in occupied spaces. In these setups, heated water circulates through a heat exchanger coil (like a car radiator), while a fan forces cooler room air across the coil. As the air passes over the hot coil, it absorbs heat and is then distributed throughout the space, warming the indoor environment.

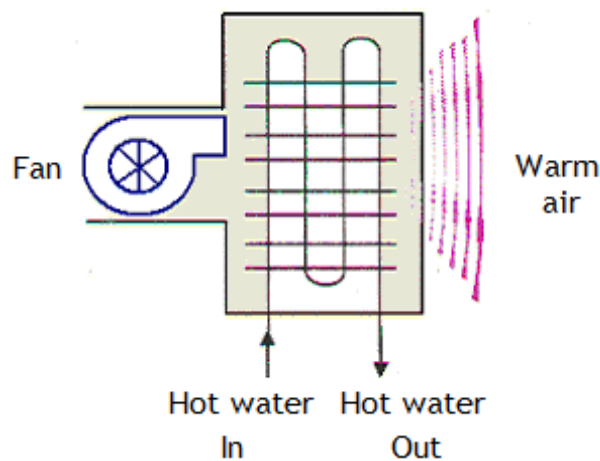

Figure 8. Forced Air Heating Schematic

Common Air Side Configurations:

- Radiant Floors: Hot water circulates through floor-embedded pipes, radiating heat upward.
- Baseboard Radiators: Fin-tube units along walls provide convective heat.
- Fan-Coil Units: Fans blow air over hot water coils to distribute heat.
- Unit Heaters: Use fans to circulate air over heated coils for space heating.

Water-Side Design Configuration (Hydronic Systems)

Water-side design governs how hot water is produced, circulated, and returned in the heating system. Using circulators operating in a closed loop allows higher water temperatures and flow rates, increasing heat output or reducing emitter size. For example:

- A 60-square-foot radiator with an average water temperature of 170°F emits heat at a rate of 150 Btu per square foot per hour, totaling 9,000 Btu per hour.
- A 45-square-foot radiator with an average water temperature of approximately 200°F emits 200 Btu per square foot per hour, also producing 9,000 Btu per hour.

Common Water-Side Configurations:

- **Series Loop:** A single loop of pipe connects the boiler to each heat emitter.
- **Parallel Loop:** Each emitter has its own loop from a manifold, better zoning and control.
- **Primary-Secondary Loop:** Separate boiler and emitter circuits connected via a hydraulic separator or heat exchanger.
- **Variable Primary Flow:** Adjusts pump speed based on load, efficient under partial loads.



These configurations can be combined to match specific building needs and system performance goals.

Classification of Hot Water Systems

Hot-water boilers are classified into three types based on their operating temperature.

- a. LTW (low temperature)
- b. MTW (medium temperature)
- c. HTW (high temperature)

Table 36. Hot Water Temperature Classification





	Boiler Type	Key Characteristics
	Low Temp Water (LTW)	<250°F, ≤160 psi; used in homes/small buildings (radiant floors, fan coils).
	Med Temp Water (MTW)	250–350°F, ~160 psi; for large buildings, district heating; needs enhanced safety.
	High Temp Water (HTW)	>350°F, ~300 psi; for industrial use; high output, complex and safety-critical systems.

Note: The LTW system operates within the pressure and temperature limits of the ASME boiler construction code.

Hot Water Supply Temperature for Space Heating

Hot water temperatures in space heating are chosen to balance comfort, efficiency, and safety. Lower temps suit homes with radiant systems, while higher temps allow quick heating in commercial settings. Standards like ASME and ASHRAE 90.1 set safe limits for temperature and pressure.

Table 37. Standard Hot Water Supply Temperatures

	Description	Guidelines/Rules of Thumb
	Typical System Design	140°F - 180°F
	ASME Guidelines	ASME B31.9: Setpoint of 180°F ± 2°F for building services hot water.
	ASHRAE 90.1	120°F – 160°F for radiant floors; 160°F – 180°F for convective systems.
	Typical Temperature ΔT	20°F – 40°F between supply and return; lower for radiant, higher for large networks.
	Energy Conservation	Vary setpoint by outdoor air temp (OAT): <ul style="list-style-type: none"> • 180°F if OAT < 20°F • 150–180°F if OAT 20–50°F • 150°F if OAT > 50°F

Notes:

- Higher temperatures yield faster heat transfer but entail higher energy consumption and risk of overheating.
- Lower temperatures are energy-efficient, and suitable for well-insulated buildings. However, these have slower heat transfer and requires larger radiators for effective heat output.

Boiler Input/Output Rating

Boilers are rated by:

- a. Input Rating: Total energy consumed; used to size fuel piping and venting.
- b. Output Rating: Usable heat delivered. The output must be sufficient to compensate for heat losses from the building, piping, and any additional heating loads such as pools or hot tubs.

Boiler Heating Capacity

The heating capacity of a boiler is measured in:

- a. British Thermal Unit per Hour (Btu/h): Energy needed to raise 1 lb. of water by 1°F per hour.
- b. Boiler Horsepower (BHP): Energy required to produce steam from 34.5 lbs. of water per hour at >212°F.





Conversion Relationship:

- 1 BHP = 33,475 Btu/h
- BHP × 34.5 = Pounds of steam produced

Boiler Output Ratings

Boiler output is rated using DOE Heating Capacity (gross output) and Net IBR Rating (usable output after piping and pickup losses). The IBR Rating reflects actual heat delivered to the space, typically about 15% less than the DOE rating, ensuring proper boiler sizing for real-world conditions.

Table 38. Boiler Ratings



	Rating Type	Description	Application
	Boiler Input Rating	Total energy consumed by the boiler (Btu/h).	Used for gas piping and venting design.
	Boiler Output Rating	Usable heat produced (Btu/h).	Match to building heat loss.
	IBR Gross Output	Heat water, excluding jacket loss.	Boiler in unheated space; piping in heated space.
	IBR Net Output	85% of IBR Gross Output (accounts for 15% distribution loss).	Both boiler and piping in unheated space.
	DOE Heating Capacity	Includes jacket and piping losses if in heated space.	Boiler and piping in heated area; applies to ≤300,000 Btu/h units.

Boiler Efficiency Ratings

Boiler efficiency reflects how well fuel is converted into usable heat. The three main types are:

- a. **Combustion Efficiency:** It measures how effectively fuel burns, based on flue gas analysis. Higher CO₂ and lower flue temps mean better efficiency.
- b. **Thermal Efficiency:** Indicates how much heat goes into the water/steam, factoring in losses through the boiler shell.
- c. **AFUE (Annual Fuel Utilization Efficiency):** A seasonal efficiency rating that includes combustion, thermal, and cycling losses, used for comparing overall boiler performance.





Table 39. Boiler Efficiency

	Efficiency Type	Rules of Thumb
	Combustion Efficiency	Measures fuel-to-flame efficiency only. Typical: 75–85%. Used for large boilers (>2.5M Btu/h).
	Thermal Efficiency	Accounts for heat transfer to water. Typical: 80–90%. Applies to 300k–2.5M Btu/h boilers.
	AFUE Rating	Seasonal efficiency incl. all losses. DOE standard for ≤300k Btu/h. Std: 80–85%, Condensing: 90–95%.

1.1.9 Improving Energy Efficiency

Boiler systems are more efficient when they run continuously with minimal cycling. Since buildings rarely need full heat output all the time, using multiple smaller boilers, such as 2×50% or 3 x 33.3% improves seasonal efficiency by reducing cycling. Boilers can be staged on as demand rises, and having an extra unit also provides redundancy for uninterrupted service.

Table 40. Energy Efficiency in Boiler Selection

	Description	Rules of Thumb
	Multiple Boilers for Efficiency	Use more than one boiler for better efficiency and reliability. <ul style="list-style-type: none"> • 2 boilers: each ~75% of load • 3 boilers: each ~50% of load
	Boiler Isolation	Fully isolate standby boilers to minimize standby/jacket heat loss.
	LO-HI-LO Burners	More efficient than ON/OFF; provide staged firing (LO-fire for part load, HI-fire for full).
	Modulating Controls	Adjust firing rate to match demand; most efficient at low fire.
	Avoid Short Cycling	Minimum burner run time: ≥5 minutes per cycle for gas boilers to prevent efficiency loss.

For boilers to run at peak efficiency, operators must attend to boiler staging, water chemistry, pumping and boiler controls, boiler and pipe insulation, fuel-air mixtures, burn-to-load ratio, and stack temperatures.





Types of Boilers

Boilers are categorized based on factors such as working pressure and temperature, fuel type, draft method, size, capacity, and whether they condense water vapor in the exhaust gases. The two main types are fire-tube and water-tube boilers.

1.1.10 Fire-tube boilers

Fire-tube boilers feature hot combustion gases flowing through tubes submerged in water. These boilers are commonly used for low to medium pressure applications for both steam and hot water heating. Their efficiency depends on factors such as the number of passes, forced-draft design, heating surface area, and updraft construction.





Table 41. Fire Tube Boilers

	Description	Rules of Thumb
	Number of Passes	3–4 passes improve efficiency by lowering exhaust temperature.
	Forced-Draft Design	Fan-forced air boosts combustion efficiency, reduces excess air.
	Heating Surface Area	Approx. 0.047 m ² /kW for effective heat transfer.
	Applications	Best for low to medium pressure systems (15–300 psi).
	Updraft Construction	Furnace located at bottom enhances combustion and safety.

1.1.11 Water Tube Boilers

Water-tube boilers feature water-filled tubes surrounded by hot combustion gases, allowing for faster heating. These boilers are typically used in large commercial or industrial settings for steam or hot water generation.









Table 42. Water Tube Boilers

	Description	Rules of Thumb
	Water Flow	Water flows inside tubes; hot gases flow around tubes in multiple passes.
	Heating Surface Area	0.065–0.085 m ² /kW for high-efficiency designs.
	Applications	High-pressure use (300–3,000+ psi): power plants, refineries, cogeneration, district heating.
	Safety & Longevity	More robust and safer than fire-tube; suitable for continuous, long-term operation.

1.1.12 The Choice of Boilers

Fire-tube and water-tube boilers are essentially the opposite in design. Fire-tube boilers are ideal for steady, consistent loads, while water-tube boilers are better for varying or fluctuating loads. Here's the detailed comparison:

Table 43. Fire Tube vs. Water Tube Boilers - Comparison

	Feature	Fire-Tube Boiler	Water-Tube Boiler
	Load Handling	Best for steady loads.	Ideal for fluctuating loads.
	Response Time	Slower due to larger water volume.	Faster due to lower water volume.
	Efficiency	Lower at high pressures, depends on passes.	Higher efficiency, especially at high pressures.
	Space Requirements	More compact; requires less space.	Requires more space, with extra components.
	Maintenance/ Lifespan	Easier to maintain but has a shorter lifespan.	Requires more maintenance, longer lifespan.
	Application	Ideal for steady heating loads.	Suited for large buildings with fluctuating demands.
	Initial Cost	Lower cost and installation.	Higher initial cost due to extra components.
	Operating Cost	Lower for steady loads, less efficient for variable loads.	More efficient for variable loads, reducing costs.

Condensing and Non-Condensing Boilers

Boilers are divided into two types: condensing and non-condensing. The key difference is how they handle combustion gases.







Condensing Boiler

A condensing boiler uses a secondary heat exchanger to extract additional heat from exhaust gases by cooling them below their dew point, causing condensation. This process recovers latent heat, boosting efficiency (90%+ AFUE). The system requires a condensate drain and allows for PVC venting due to cooler exhaust gases.

Non-Condensing Boiler

Non-condensing boilers do not have a secondary heat exchanger, so exhaust gases leave the stack above 140°F, resulting in lower efficiency (80-85% AFUE) and higher fuel consumption. They use metal venting and don't require a condensate drain, making them ideal for high-temperature applications like baseboard heating.







Table 44. Condensing Boilers vs Non-condensing Boilers

	Feature	Condensing Boiler	Non-Condensing Boiler
	Heat Recovery	Recovers heat from exhaust via secondary heat exchanger	Vents exhaust without reclaiming heat
	Efficiency	High (90%+ AFUE)	Moderate (80–85% AFUE)
	Flue Gas Temp	Cool (~100–120°F), potential corrosion from sulfur compounds, supports PVC venting.	Hot (>140°F), requires metal venting
	Condensation	Produces condensate; needs drain	No condensation: no drain needed
	Operating Cost	Lower due to higher efficiency	Higher due to heat loss
	Initial Cost	Higher (advanced components)	Lower (simpler design)
	Ideal Application	Low-temp systems (e.g., radiant heating)	High-temp. systems (e.g., baseboard)

Boiler Draft

Boilers rely on draft systems to move combustion gases through the boiler and safely vent them out. Draft can be created naturally by temperature differences or mechanically using fans or blowers.

Table 45. Natural Draft vs. Mechanical Draft Boiler

	Feature	Natural Draft Boiler	Mechanical Draft Boiler
	Airflow Control	Relies on buoyancy of hot gases for airflow	Uses fans/blowers to control airflow
	Chimney Requirement	Requires tall chimney for draft	Shorter chimneys are sufficient
	Combustion Air	50 CFM per 100 MBH (Note: 1 MBH = 1,000 Btu/h)	21 CFM per 100 MBH (add 25% if barometric damper is used)
	Efficiency	Lower	Higher due to optimized combustion
	Complexity	Simpler, fewer moving parts	More complex, additional mechanical components
	Maintenance	Low maintenance	Requires regular maintenance of fans and controls
	Application	Typically for low-pressure systems	Common in modern, high-efficiency heating systems

Mechanical draft systems can operate in three main ways:

- a. Induced draft systems use a fan to pull flue gases through the exhaust stack, creating negative pressure within the furnace.
- b. Forced draft systems push combustion air into the furnace using a fan, generating positive pressure.
- c. Balanced draft systems combine both methods, using a forced draft fan for air supply and an induced draft fan for exhaust control, typically maintaining slightly negative furnace pressure for stable operation.





Boiler Room Ventilation and Smoke Exhaust

In the heating system, there are necessarily two interconnected systems:

- Ventilation - Provides high-quality fuel combustion through airflow.
- Smoke exhaust - smoke removal

Both systems are no less important than boiler equipment.

Table 46. Ventilation Air vs. Exhaust Air

	Feature	Ventilation Air (Intake Air)	Smoke Exhaust (Vent Air)
	Purpose	Supplies oxygen for fuel combustion	Removes combustion byproducts (CO, NO _x , H ₂ O, etc.)
	Control	Natural or mechanical (forced) draft	Natural or induced draft (fans)
	Benchmark	~50 CFM per 100,000 Btu/h input (indoor); use ducts for outdoor air (if needed)	Vent size per NFPA 54, based on input and type; slope min. ¼ in/ft for horizontal
	Impact on Efficiency	Directly affects combustion quality (complete/incomplete)	Poor venting causes heat loss: high-efficiency systems recover more from exhaust
	Safety Concern	Inadequate air → CO production, flame rollout; follow IFGC/IMC Section 304	Improper venting → backdraft, CO leaks; follow NFPA 54, ANSI Z223.1, UL 1738









Ventilation Air

Ventilation is essential for safe combustion, heat removal, and maintaining air quality. Two key air types are required:

- Combustion Air – Air needed to support the combustion of fuel.
- Ventilation Air – Air needed to maintain safe room conditions, heat dissipation from equipment, and ensure air quality.

Standard guidelines are used to calculate the required air volume for boiler rooms with gas or oil-fired firetube boilers.

Table 47. Boiler Room Ventilation

	Parameters	Rules of Thumb
	Combustion Air	7–15 CFM per BHP (1 BHP = 33,475 Btu/h), varies by burner type and fuel.
	Ventilation Air	Minimum 1–2 CFM per sq. ft. of boiler room floor area or equal to combustion air in enclosed rooms.
	Net Free Air Opening	Net Free Air Opening = Required CFM ÷ Acceptable Velocity (FPM).
	Acceptable Velocity	250 FPM up to 7 ft elevation; 500 FPM above 7 ft elevation.
	Louver Sizing	Gross Opening = Free Area Opening ÷ % Free Area; assume 60% free louver area unless manufacturer specifies otherwise.
	Minimum Gross Opening	4–6 in ² unrestricted airflow per BHP.
	Number of Openings	Minimum two permanent air openings in boiler room outer walls; 1 in ² per 2,000–4,000 Btu/h. Check local codes.
	Outdoor Air Intake	Place openings 12" from the ceiling and floor; avoid recirculation, obstructions, fine mesh screens; use mechanical fans if needed.
	CO Detection	Install carbon monoxide detectors in boiler rooms for safety.

Note: These figures are adequate for installations up to 1000 feet above sea level (FASL). For installation above 1000 FASL, add 3% additional air for each 1000 FASL (or portion thereof) to allow for the density change in air at higher altitudes.

Example: Combustion & Ventilation Air Calculation

Boiler Size: 200 BHP

Installation: 500 feet above sea level (FASL)

Combustion Air Requirement: 10 CFM per BHP (average rule)

Ventilation Air Requirement: Equal to combustion air

Total Air Required: $200 \text{ BHP} \times 10 \text{ CFM} \times 2$ (for both combustion + ventilation) = 4,000 CFM

Altitude correction: Nil

Louver Free Area: Assume 60% (0.60) effective

Max Louver Face Velocity: 500 FPM

Step-by-Step Louver Sizing

Step 1: Determine Free Area Needed







$$\text{Free Area (sq ft)} = \frac{4,000 \text{ CFM}}{500 \text{ FPM}} = 8 \text{ sq ft}$$

Step 2: Adjust for Louver Free Area (%)

$$\text{Gross Louver Area} = \frac{8}{0.6} \approx 13.3 \text{ sq ft}$$

Recommended Louver Size: Approx. 3 ft × 4.5 ft or two 2.5 ft × 2.7 ft louvers

Table 48. Codes/Standards for Ventilation Air

	Code / Standards	Description
	IMC (International Mechanical Code)	Sets ventilation, combustion air, and exhaust duct rules for mechanical rooms; includes sizing, placement, and clearance criteria. Widely adopted in the U.S.
	NFPA 54 (National Fuel Gas Code)	Covers gas piping, combustion air, and venting requirements for gas-fired equipment.
	NFPA 31 (Standard for Installation of Oil-Burning Equipment)	Regulates installation and venting of oil-fired boilers and furnaces.
	ASHRAE 62.1	Specifies minimum ventilation and exhaust rates to maintain indoor air quality.
	IBC (International Building Code)	Governs structural and fire safety for mechanical rooms; references IMC and related standards.
	Local Building Codes & Manufacturer Requirements	Must comply with local regulations and boiler manufacturer guidelines for air supply, vent sizing, and clearances.

These standards ensure the safety, efficiency, and code compliance of boiler room ducting arrangements. Always verify with the Authority Having Jurisdiction (AHJ) for local amendments and approval.

Boiler Exhaust (Vent Categories)

Boiler exhaust categories define how combustion gases are safely vented from the system. These categories are based on factors such as flue gas temperature, pressure, potential for condensation, and whether the exhaust relies on natural or mechanical draft. Each vent category specifies the appropriate materials, system configuration, and installation standards required to ensure proper exhaust flow and to prevent risks such as corrosion, condensation damage, or backdrafting.

Table 49. Boiler Vent Categories

Category	Type	Pressure	Flue Temp.	Venting	Boiler Type
I	Non-condensing, Natural Draft	Negative	High (above dew point, >250°F)	Chimney or Metal Vent (Type B); NFPA 54 compliant	Standard atmospheric boilers
II	Condensing, Negative Pressure	Negative	Low (below dew point, <140°F)	Corrosion- resistant venting; UL 1738 materials	Specialty condensing boilers
III	Non-condensing, Positive Pressure	Positive	High (above dew point)	Sealed venting system; stainless steel or AL29-4C	Power-vented non-condensing boilers
IV	Condensing, Positive Pressure	Positive	Low (below dew point, ~100– 130°F)	Sealed, corrosion- resistant vent (e.g., PVC, CPVC); UL 1738	High efficiency condensing boilers

Key Takeaways:

- Category I: Traditional, non-condensing boilers using chimneys. ONLY Category I appliances may use B vent*.
- Category II: Rare, used for specialized applications where low-temperature flue gases are vented with negative pressure.
- Category III: Uses a fan to push hot gases out under positive pressure; needs sealed venting.
- Category IV: High-efficiency condensing boilers; flue gases cool below condensation point, requiring corrosion-resistant vent materials (e.g., PVC, CPVC, or stainless steel).

B-Vent

B-Vent (also called Type B Gas Vent) is a double-wall, metal venting system designed for venting non-condensing gas-fired appliances. It consists of an inner aluminum liner and an outer galvanized steel shell, creating an air insulation layer that helps maintain flue gas temperature and improve draft performance. B-Vent relies on natural draft and must be installed vertically to allow proper exhaust flow. B-Vent is not suitable for high-efficiency condensing boilers (Category II & IV) or positive pressure venting systems (Category III & IV) because they cannot handle condensation or pressurized exhaust.

The principles of combustion and vent requirements are already discussed in the previous chapter on Furnace. The rules are essentially the same.

Boiler Room Sizing

Boiler room sizing is influenced by boiler capacity, layout, clearances, and ventilation. The room should provide enough space for boiler/s, pumps, expansion tanks, piping, and controls, with at least 24–36 inches of clearance for safe access and maintenance. Additional space may be required for multiple units, future upgrades, or ancillary equipment like water treatment systems or buffer tanks. Adequate ventilation must be included for combustion air and heat removal. A well-sized boiler room ensures efficient operation, serviceability, and compliance with local codes.



Figure 9. Boiler Plant Room

We will check with an example.

Estimate the size of a boiler/hot water heater for a 22000 sq ft commercial office. Assume 30 Btu/sq ft. heating load.

Total heat = $22000 \times 30 = 660000$ Btu/h or 19.71 HP ----- [1 Boiler HP = 33,475 Btu/h].

Select 20 HP Boiler

Boiler Dimensions

Length = 92 inches or 7ft. 8”

Width = 47 inches or 3ft. 11”

Height = 60 inches or 5 ft.

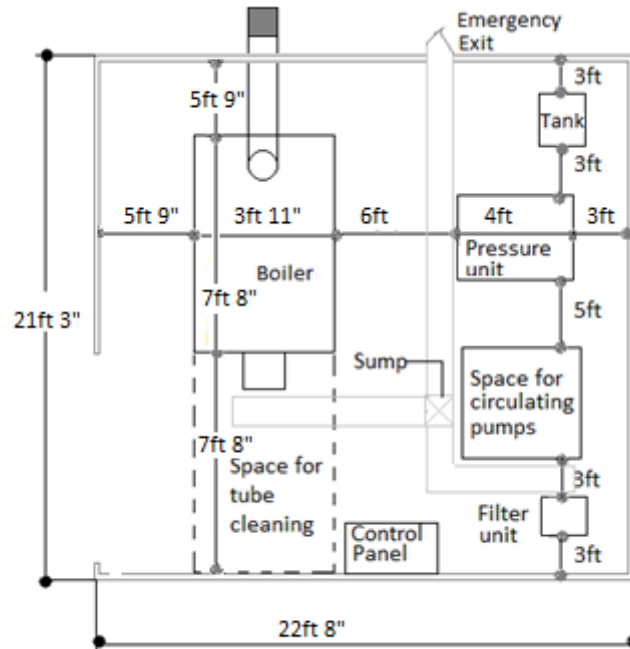

Boiler Room Layout

An average residential boiler for 2000 sq.-ft size is around 2 feet wide x 1.5 feet deep and 3 feet high.

Boiler Room- Egress Requirements (IBC 1006.2.2.1)

Two exit access doorways are required in boiler and furnace rooms where the area is over 500 square feet and any fuel- fired equipment exceeds 400,000 British thermal units (Btu) input capacity. Where two exit access doorways are required, one is permitted to be a fixed ladder or an alternating tread device. Exit access doorways shall be separated by a horizontal distance equal to one-half the length of the maximum overall diagonal dimension of the room.

Fuel Consumption



Hot water boilers are fuelled by natural gas, liquid propane (LPG), or Fuel oil#2.

To estimate fuel consumption per Boiler Horsepower (BHP), we start with the basic rules of thumb:

1 Boiler Horsepower (BHP) = 33,475 Btu/hr

Using this, here's the approximate fuel consumption per BHP per hour for each fuel type.

Table 50. Fuel Consumption per BHP Boiler Rating

	Fuel Type	Heating Value	Fuel Consumption per BHP assuming 100% efficiency
	Fuel Oil #2	~140,000 Btu/gallon	0.24 gal/hr per BHP
	Natural Gas	~1,000 Btu/cubic foot	33.5 ft ³ /hr per BHP
	LPG (Propane)	~2,500 Btu/cubic foot	13.4 ft ³ /hr per BHP

Note: These are general estimates. Actual consumption depends on boiler efficiency. For example, at 80% efficiency, fuel input would need to be higher around 41.84 ft³/hr per BHP for natural gas.

Equation 2. Boiler Fuel Consumption

Determine Input Energy Required:

$$\text{Input Energy} = \frac{\text{Output Energy}}{\text{Efficiency}} = \frac{33,475}{0.8} = 41,843.75 \text{ Btuh}$$



Convert Input Energy to Gas Volume:

$$\text{Gas Consumption} = \frac{41,843.75 \text{ Btuh}}{1,000 \text{ Btu/ft}^3} = 41.84 \text{ ft}^3/\text{hr per BHP}$$

Boiler Control Strategies

A boiler operates at maximum load when functioning at its rated capacity, but if the heat demand fluctuates, it operates at a varying load. Boilers are typically controlled using one of two strategies: variable temperature control and constant temperature control.

Table 51. Boiler Control Strategies

	Control Strategy	Rules of Thumb
	Variable Temperature Control	Adjust water temperature with outdoor temp or load; used in space heating for efficiency.
	Constant Temperature Control	Maintain fixed water temperature; typical for domestic hot water, pools, hot tubs.

Safety Controls

A boiler includes at least two key safety controls:

- a. Pressure Relief Valve – Releases excess pressure to prevent dangerous buildup.
- b. Temperature Limit Controller – Regulates normal heating and shuts down the system if temperatures exceed safe limits.

Minimum Efficiency Requirements

Boilers minimum efficiency is listed in Table 6.8.1-6, ASHRAE Standard 90.1. Extract depicted below.

Table 52. Boiler Efficiency Requirements (ASHRAE Std. 90.1)

Equipment Type	Subcategory or Rating Condition	Size Category (Input)	Minimum Efficiency	Efficiency as of 3/2/2020	Test Procedure
Boilers, hot water	Gas fired	<300,000 Btu/h	82% AFUE	82% AFUE	10 CFR Part 430
		≥300,000 Btu/h and ≤2,500,000 Btu/h	80% Et	80% Et	10 CFR Part 431
		>2,500,000 Btu/h	82% Ec	82% Ec	
	Oil fire	<300,000 Btu/h	84% AFUE	84% AFUE	10 CFR Part 430
		≥300,000 Btu/h and ≤2,500,000 Btu/h	82% Et	82% Et	10 CFR Part 431
		>2,500,000 Btu/h	84% Ec	84% Ec	
Boilers, steam	Gas fired	<300,000 Btu/h	80% AFUE	80% AFUE	10 CFR Part 430
	Gas fired , all, except natural draft	≥300,000 Btu/h and ≤2,500,000 Btu/h	79% Et	79% Et	10 CFR Part 431
		>2,500,000 Btu/h	79% Et	79% Et	
	Gas fired , natural draft	≥300,000 Btu/h and ≤2,500,000 Btu/h	77% Et	79% Et	10 CFR Part 431
		>2,500,000 Btu/ha	77% Et	79% Et	
	Oil fire	<300,000 Btu/h	82% AFUE	82% AFUE	10 CFR Part 430
		≥300,000 Btu/h and ≤2,500,000 Btu/h	81% Et	81% Et	10 CFR Part 431
		>2,500,000 Btu/h	81% Et	81% Et	

1.1.13 Energy Star Label

Boilers that meet or exceed an 85 percent efficiency rating are labelled as Energy Star compliant and are provided with the Energy Star logo.

CHAPTER 3: HYDRONIC SYSTEM AUXILIARIES

Hydronic systems use water to transfer thermal energy for space heating or cooling, relying on key components like boilers or chillers as heat sources, circulating pumps for water movement, and a network of pipes delivering water to heat emitters like radiators or fan coils. Expansion tanks, valves, and controls enhance efficiency and safety. Proper pump and piping design ensures efficient operation, comfort, and system reliability. This chapter covers essential guidelines and practical rules of thumb for selecting and designing circulator pumps, piping, heat emitters, and other auxiliaries to ensure reliable and efficient system performance.

Circulator Pumps

Circulator pumps move hot water from the boiler to heat emitters throughout a building. In closed-loop systems, they generate a pressure difference to maintain flow, hence the term "circulators", rather than lifting water. Selection is based on the required flow rate (GPM) and head (ft of water) to overcome resistance from pipes, fittings, and terminal units.

Pump Options

Circulator pumps, typically centrifugal, come in different configurations for various needs:





Figure 10. End Suction, Split Casing and Vertical Inline Pumps

- a. End-suction pumps: Pull water in from one end and discharge it radially; ideal for low-flow, high-head applications.
- b. Horizontal split-case pumps: Have a split body with the water inlet and outlet on the same axis. Their design allows easy access to internal components for maintenance, making them ideal for large-capacity HVAC systems.
- c. Vertical in-line pumps: Installed directly in the piping with suction and discharge connections aligned in a straight line. They are compact and efficient for moderate flow

rates, making them an excellent choice for installations with limited floor space.

Table 53. GPM and Head Application Range of Different Pumps

	Pump Type	Flow Range (GPM)	Head Range (ft)	Typical Use	Standards/References
	End Suction	50 – 1,000+	50 – 200	Small to medium HVAC systems	ANSI/HI Standards, ASHRAE Guides
	Split Casing	500 – 5,000+	100 – 600	High flow and head applications	ANSI/HI Standards
	Vertical In-line	50 – 1,500	50 – 300	Space-limited moderate flow	ASHRAE Handbook, ANSI/HI Standards

Flowrate (GPM)

The flow rate of a circulator pump in a space heating system depends on the heat load and the temperature difference (ΔT) between supply and return water. It is calculated using the equation:

Equation 3. Circulator Flowrate (GPM)

$$Q = \frac{\text{Btu/h}}{500 \times \Delta T}$$

Where:

- Q = Flowrate (gallons per minute, GPM)
- Btu/h = Heat loss of the building (British thermal units per hour)
- ΔT = Temperature difference between supply and return ($^{\circ}\text{F}$)
- 500 = Constant representing water's heat capacity at 60°F , calculated by multiplying:
 - Weight of 1 gallon of water = 8.33 lbs./gal
 - Specific heat of water = 1 Btu/lb. $^{\circ}\text{F}$
 - Minutes/hour = 60 min/hr.

From the equation, it's clear that if ΔT decreases, GPM must increase to maintain the same Q (heat output). For example, with a boiler capacity of 500,000 Btu/h, the required flowrates for different temperature ranges would be:

	Boiler Capacity (Btu's)	Flowrate (GPM)			
		@20°F ΔT	@25°F ΔT	@30°F ΔT	@40°F ΔT
	500,000	50 GPM = 50	40 GPM = 40	33 GPM 33	25 GPM = 25

Notes:





- Lower ΔT design, requires higher flowrates (GPM) → larger pumps and pipes, increases pumping energy and operating costs, and may limit system efficiency, especially in condensing boilers (less condensation).
- Higher ΔT design, reduces flowrates (GPM) → smaller pumps and pipes, lowers pumping energy and initial costs but requires high-temperature supply water and may lead to uneven heating or slower response times. Not ideal for low-temp systems like radiant floors.

Note: The standard flowrate formula using a constant value of 500 in denominator assumes 60°F water temperature. As water heats up, its density decreases but specific heat increases, and volume expands. Since the opposing effects of density and specific heat balance out, no additional temperature corrections are needed in typical hydronic designs for standard HVAC applications.

Head Loss

To select the right circulator pump, you need both the required flowrate (GPM) and the system's pressure drop, caused by friction as water moves through pipes. This resistance, measured in feet of head, must be overcome by the pump. Pipe sizing charts and industry standards help determine the pressure drop for any flowrate through any pipe size. The industry standard is to select a pipe size that offers the frictional resistance between 1–4 feet per 100 feet of piping. In closed-loop systems, building height doesn't affect head loss as returning water counterbalances the supply. Therefore, static pressure from height is not included.

Table 54. Pump Head Loss

	Description	Rules of Thumb
	Circulator Pump Sizing	Size by required GPM and total system head loss due to pipes, fittings, and equipment resistance.
	Frictional Resistance	Caused by piping and fittings, not building height in closed-loop systems.
	Fluid Velocity	Recommended velocities: Copper pipe 2–4 fps, Steel 3–8 fps, Plastic 2–5 fps.
	Head Loss Range	Target 1–4 feet of head loss per 100 feet of pipe.

Rules of Thumb for Estimating Head Loss (for small systems)





- a. Measure the longest piping run (in feet).
- b. Multiply by 1.5 to get Total Equivalent Length (TEL)*.
- c. Multiply TEL by 0.04 to estimate head loss in feet of water.

*Total Equivalent Length (TEL) is the total measured length of the longest route piping + equivalent lengths of valves and fittings.

Head and Pressure

Pressure is the force a fluid exerts per unit area (measured in psi or Pa), while head is the height the fluid can be lifted (measured in feet or meters). Both indicate the energy provided by a pump, but pressure relates to force, and head relates to elevation.

Table 55. Pump Pressure vs. Head

	Parameter	Rules of Thumb
	Pressure	Dependent on fluid density and gravity. Denser fluids create higher pressure on the same head.
	Head	Independent of fluid density; fixed head lifts any liquid to the same height.
	System Design Consideration	Head relates to system resistance and energy, not fluid density or mass.
	Relationship (Head & Pressure)	1 psi = 2.31 feet of head; 1 foot of head = 0.433 psi pressure difference.

Pump Characteristics

Each pump has a unique characteristic curve that shows the pressure it can generate at varying flow rates. This differs from the system characteristic curve, which represents the relationship between flow and pressure loss within the piping circuit.

1.1.14 Pump Operating point

The point where the pump curve intersects the system curve is known as the operating point, where the pump's pressure output matches the system's pressure loss at a specific flow rate. Any change in system pressure drop shifts the system curve and, consequently, the operating point. An increase in pressure drop reduces flow, unless the pump speed is increased to compensate.

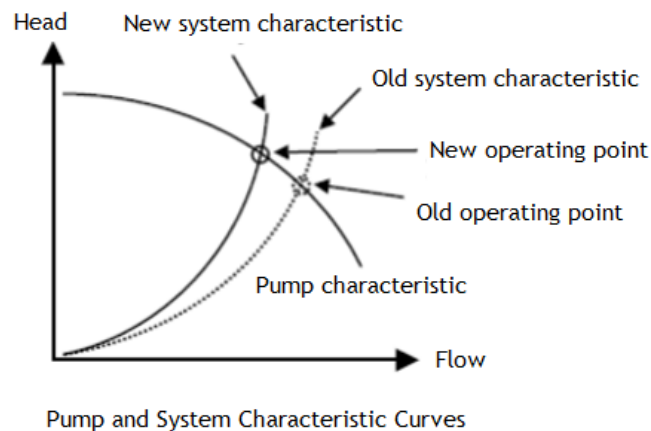





Figure 11. Pump Characteristic and System Curve

	Description	Rules of Thumb
	Steep Pump Curve	Large pressure change with small flow change; suitable for variable demand systems.
	Flat Pump Curve	Gradual pressure changes with flow; suited for stable pressure systems.
	VSD Benefits	Adjusts pump speed, reduces power use; used in HVAC & variable load systems.
	Power Reduction (Affinity)	Power varies with speed ³ ; enables significant energy savings.

1.1.15 Pump Location

The ideal location for a circulator pump is placed downstream of the boiler and expansion tank, pumping water away from the boiler and into the heating system. This is often referred to as "pumping away" or "pumping out".

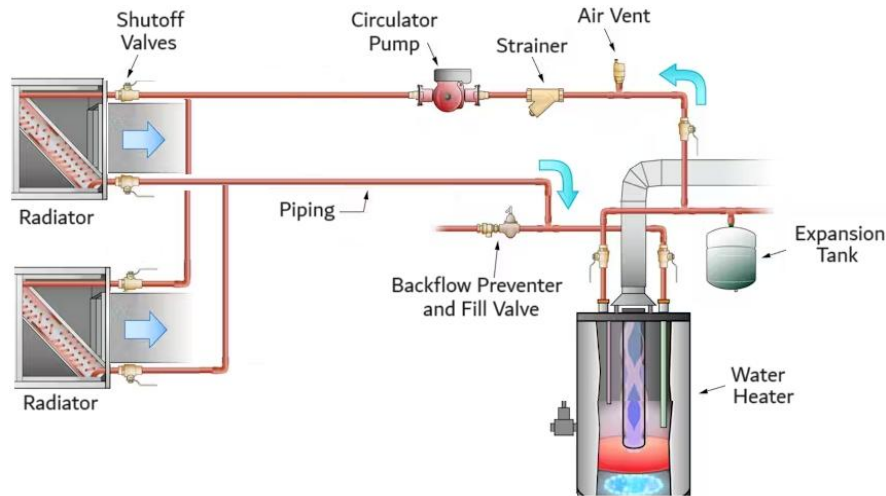



Figure 12. Circulator Pump Location Downstream of the Boiler

Why is pumping away (downstream) preferred?

- Keeps boiler inlet pressure low, avoiding the need for high-pressure-rated boilers (standard is ≤ 150 psi operating pressure).
- Increases static pressure at the pump inlet, reducing cavitation risk and pump damage.
- Improves air removal, preventing air pockets and circulation issues.
- Enhances temperature control, especially with mixing valves.
- Avoid pressure surges at relief valves, preventing pressure relief valve to dribble or open every time a pump turns on.

Table 56. Pump Location

	Pump Location	Pros	Cons
	Downstream Boiler (Pumping Away)	<ul style="list-style-type: none"> ✓ Reduces cavitation risk ✓ Stabilizes system pressure ✓ Improves temperature control. 	<ul style="list-style-type: none"> ✗ Requires higher pump head ✗ Higher temperature may reduce pump lifespan.
	Upstream of Boiler (Pumping Into)	<ul style="list-style-type: none"> ✓ May reduce pump head requirements ✓ Protects pump from high temperatures 	<ul style="list-style-type: none"> ✗ Increases cavitation risk ✗ Less stable system pressure ✗ Poorer temperature control ✗ Higher risk of boiler thermal shock

Note: In some complex systems, upstream pumping may be necessary but carefully evaluate potential risks.

Pumping Configurations

A variety of pumping configurations are used in the hydronic systems.

Single-Pump System (Primary-Only Circulation)

A single circulator pump moves water from the boiler to the entire heating zones. Best for small residential systems with low flow requirements. However, it offers limited zoning capabilities, as the entire system operates at a uniform temperature.

Multiple-Pump Systems (Parallel or Series)

Two or more pumps are installed in parallel to handle the same heating load. Check valves are installed to prevent recirculation through an OFF pump. Parallel pumps provide redundancy, ensuring system operation if one pump fails or requires maintenance. Pumps can be arranged in series to boost pressure in systems with high resistance.

Primary-Secondary Pumping System

This configuration separates the boiler loop (primary loop) from the distribution loops (secondary loops) serving terminal units e.g., radiators, baseboards, and fan coils. A primary circulator pump maintains constant flow through the boiler, while secondary circulators control flow through individual heating zones. A hydraulic separator or closely spaced tees prevent interference between loops and allows for independent control of flow rates and temperatures in each loop.

Zone Pumping System

This configuration uses multiple circulator pumps, each dedicated to a specific heating zone. Zone valves and thermostats control the operation of individual pumps, allowing for independent temperature control in different areas of the building. The arrangement provides greater comfort and energy efficiency, as heat is only supplied to zones that require it.

Zone Valves with a Single Pump

A single circulator pump is used with zone valves that open and close based on thermostat calls. Zone valves direct water flow to different areas.

Variable-Speed Pumping System (With VSDs)

A variable-speed drive (VSD) pump adjusts flow rate based on the system's heat demand. The system improves energy efficiency by reducing pump power consumption during periods of low heat demand.

Each configuration has its advantages and disadvantages, and the choice of configuration depends on factors such as:

- System size and complexity
- Boiler type and capacity
- Heating load and temperature requirements
- Energy efficiency and cost considerations









Table 57. Comparison Table of Pumping Configurations

Configuration	Applications	Pros	Cons
Single-Pump System	Small homes, simple HVAC	Low cost, easy maintenance	Limited zone control
Multiple-Pump System	Large systems, redundancy needed	Backup, flexible operation	Higher cost, more space required
Primary-Secondary Pumping	Large buildings, multiple zones	Prevents short cycling	Complex piping, higher cost
Zone Pumping	Multi-zone, radiant heating	Independent zone control	More pumps, higher maintenance
Zone Valves + Single Pump	Homes with multiple zones	Lower cost than zone pumps	Slower response, pressure swings
Variable-Speed Pumping	High-efficiency systems	Energy savings, smooth control	Higher upfront cost, complex controls

Pump Selection Criteria

The pump must be chosen to generate the required flow rate and pressure to overcome system resistance and ensure adequate heat transfer. The HVAC engineer will need to make decisions regarding the following parameters:

Table 58. Selection Criteria for Pumps

	Parameters	Criteria
	Capacity (Flowrate)	Determined by system heat load (Btu/h) and ΔT ; typical units in gallons per minute (GPM).
	Total Head (feet)	Pressure to overcome elevation, friction, valves, coils; system-specific calculations required.
	Pump Types	Centrifugal (end-suction, split-case, vertical inline); positive displacement for precise dosing.
	Efficiency	Select pumps near Best Efficiency Point (BEP); follow ASHRAE 90.1 efficiency standards.
	Operating Speed	Prefer 1750 RPM for quieter operation and standardization.
	Control	Use throttling valves or Variable Frequency Drives (VFD) for energy-efficient control.
	NPSH	Available NPSH must exceed required NPSH to prevent cavitation (ASME/ANSI standards).
	Space	Choose compact designs fitting available mechanical room space.
	Cost	Balance upfront purchase price against long-term operating and maintenance costs.



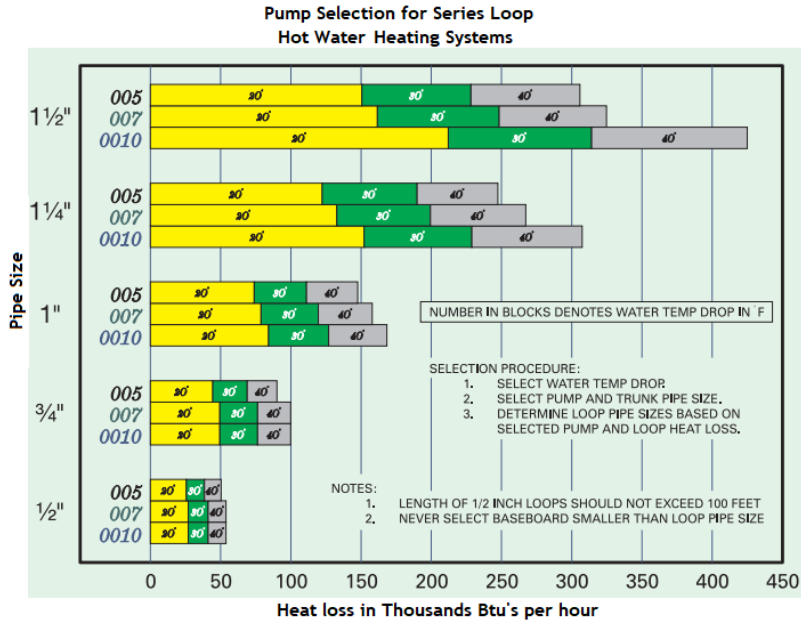

Use the chart below for quick selection based on heat load and pipe size used. The chart is from “Taco” for their “00” Series Circulators. Similar charts are available from other circulator manufacturers.



Understanding Cavitation

Cavitation in hot water heating systems occurs when the pressure at the pump inlet drops below the water’s vapor pressure, causing vapor bubbles to form. These bubbles collapse violently within the pump impeller, leading to noise, vibration, and long-term damage to pump components. In hydronic systems, cavitation is most likely to happen in high-temperature loops or when pumps are improperly placed or sized.

Table 59. Tackling Cavitation

	Cavitation	Rules of Thumb
	Cavitation Cause	Occurs when inlet pressure < vapor pressure, causing damaging vapor bubbles.
	Preventing Cavitation	Ensure NPSHA > NPSHR (Net Positive Suction Head Available > Required).
	Pump Location	Avoid high points or upstream restrictive valves; locate pump away from expansion tank.
	Susceptible Systems	Boiler feed, cooling towers, open loops, and high-temperature water systems are most vulnerable.

Pump Affinity Laws

Ever wonder how a pump's performance changes with speed (RPM)?

The affinity laws provide a simple way to estimate these changes.

Equation 4. Flow rate vs. Pump Speed

$$\text{Flow rate (Q): } \frac{Q1}{Q2} = \frac{N1}{N}$$

- Flowrate is directly proportional to pump speed.

Equation 5. Head pressure vs. Pump Speed

$$\text{Head pressure (H): } \frac{H1}{H2} = \left(\frac{N1}{N2}\right)^2$$



- Head pressure is proportional to the square of the pump speed.

Equation 6. Power vs. Pump Speed

$$\text{Power consumption (P): } \frac{P1}{P2} = \left(\frac{N1}{N2}\right)^3$$

- Power consumption is proportional to the cube of the pump speed.

Table 60. Affinity Laws for Pumps

	Parameters	Rules of Thumb
	Pump Speed and Flowrate	Doubling speed doubles flowrate
	Flowrate and Head Pressure	Doubling speed quadruples head pressure
	Flowrate and Power Consumption	Doubling speed increases power use eightfold

For example, doubling a pump's flow from 100 to 200 GPM increases the power eightfold (10 to 80 HP).

Pump Power Consumption

Pump's power consumption depends on flowrate, pump head and efficiency of the pump and motor.

Equation 7. Pump Power (BHP)

$$\text{BHP} = \frac{\text{GPM} \times \text{TDH} \times \text{SG}}{(3960 \times \text{Pump } \eta)}$$

where:

- BHP = brake horsepower or shaft power
- GPM = water flow, gallons per minute
- TDH = Total Dynamic Head, feet
- SG = Specific Gravity, for water it is 1
- Pump η = Pump efficiency in decimals from its pump curves

Equation 8. Power Input

The power input will depend on the motor efficiency and shaft power (BHP) requirement.

$$\text{HP} = \frac{\text{BHP}}{\text{Motor } \eta}$$



Or

$$\text{KW} = \frac{\text{BHP} \times 0.746}{\text{Motor } \eta}$$

Where:

- KW = Pump power input
- Motor η = Motor efficiency in decimals
- 0.746 = Conversion factor, 1KW = 0.746 x BHP

Table 61. The 3000 Rule for Estimating Pump HP

	Pump Horsepower	Rule of Thumb
	The 3000 Rule	1 HP pump \approx 3000 GPM at 1 ft head at 75% efficiency
	Simplified Power Equation	Use simplified pump power equation for 75% efficiency: Pump Power (HP) = (Flowrate (GPM) \times Head (ft)) \div 3000 Adjust power calculation for actual pump efficiency if different from 75%

Example

How large is the motor and how much will it cost to operate the motor on a cooling water pump with a capacity of 1500 GPM at 30 feet of head pressure? Assume 75% pump efficiency.

$$\frac{1500 \text{ (GPM)} \times 30 \text{ (ft)}}{3000 \text{ GPM per ft head}} = 15\text{hp}$$

Equation 9. Power Consumption

Power energy consumption (kWh) = Power input x operating hours

Example

Let's say you have a pump that operates for 12 hours a day, with an average power input of 5000 watts. You want to estimate the total power consumption of the pump for a month.

Multiply the power rating of the pump by the number of hours it operates in a day.

Daily energy consumption = 5,000 watts * 12 hours = 60,000 watt-hours or 60 kWh.

To calculate the monthly energy consumption, multiple the daily energy consumption by the number of days the pump operates in a month.







Monthly energy consumption = 60 kWh * 30 days = 1,800 kWh

So, the estimated power consumption of the pump operating for 12 hours a day for a month would be 1800 units of electricity.

Meeting Efficiency Standards

Below is a table summarizing the minimum performance requirements for centrifugal pumps according to ASHRAE 90.1-2019:

Table 62. ASHRAE 90.1 – 2019: Minimum Efficiency Requirements





	Parameter	Requirement
	Pump Efficiency	$\geq 70\%$ (<7.5 HP), $\geq 75\%$ (≥ 7.5 HP)
	Motor Efficiency	$\geq 90\%$ (<7.5 HP), $\geq 94\%$ (≥ 7.5 HP)
	Motor Power Factor	≥ 0.90 (<200 HP), ≥ 0.95 (≥ 200 HP)
	Motor Service Factor	≥ 1.0 (<200 HP), ≥ 1.15 (≥ 200 HP)
	Pump Motor Size	NEMA Premium (<200 HP), IEEE 841 (≥ 200 HP)
	Vibration Limit	Max 0.15 in/sec for pumps >10 HP

Note: This is a simplified summary. Refer to the ASHRAE 90.1 latest standard for complete and accurate information on the minimum performance requirements for centrifugal pumps.

Final Takeaway....

When selecting pumps, engineers often focus on pump efficiency, but accurately estimating the required flow rate and head is equally important. Oversizing can significantly impair system efficiency, for example, selecting a pump with double the required head may reduce efficiency to 35%, while oversizing the flow can bring it down to around 17.5%. Aim to operate the pump near its Best Efficiency Point (BEP), while ensuring accurate sizing for optimal performance and energy savings.





Table 63. Recommendations for Right Pump Sizing

	Recommendations	Rules of Thumb
	Avoid Oversizing	Limit safety margin to 10–15%.
	Flow & Head Priority	Match flowrate and head over minor efficiency gains.
	Target Efficiency	Aim for 70–85% pump efficiency in HVAC; see ASHRAE 90.1.
	Code Reference	ASHRAE 90.1, DOE Pump Efficiency Rule, NEMA MG-1 (motor std.)

Overview of Hydronic Piping

A hot water piping system distributes heated water from the boiler to terminal units. Common piping include copper, steel, and PEX, selected for their pressure rating, temperature, and cost. A well-designed hot water piping system ensures efficient flow performance, energy efficiency, and long-term reliability.

Table 64. Hydronic Piping Materials

	Piping Material	Pipe Size	US Standard	Applications	Benchmark Figures
	Welded Mild Steel	½"–6"	ASTM A53/A106, Sch. 40	Moderate pressure & temperature systems	285 psi at 100°F, up to 800°F
	Welded Carbon Steel	8"–18"	ASTM A53/A106, Sch. 40/80	High-pressure/high-temp. HVAC & process piping	285 psi at 100°F, up to 800°F
	ERW (Carbon Steel)	20"–24"	ASTM A53, API 5L Gr. B, X/XXS	Large diameter, industrial/commercial mains	285 psi at 100°F, up to 800°F
	Copper (Type L)	Up to 2"	ASTM B88	Hot/chilled water, refrigerants	400 psi, up to 400°F
	PEX	Up to 1"	ASTM F876, F877	Radiant heating, snow melt, domestic hot water	160 psi, up to 200°F



Pipe Sizing and Calculations

Pipe sizes determine how well hot water is pushed around the system. Undersized pipes restrict flow, while larger pipes allow faster delivery, improving heat retention and reducing boiler load. Both piping and circulator must be correctly sized for the required flow, slightly oversizing is better than under sizing. Two commonly used criteria for pipe sizing are: velocity method and friction method.

Pipe Sizing based on Velocity Criteria

The velocity method sizes pipes to keep water velocity within 2–8 feet per second (fps), depending on the pipe material and application. This helps prevent noise, erosion, and sediment buildup, while ensuring efficient heat transfer. Lower velocities are ideal for residential or quiet zones, while higher speeds may suit large commercial networks. Proper velocity control supports system performance, comfort, and longevity.

Table 65. Recommended Velocity Limits

	Application	Velocity Range (ft/s)
	Branch lines to radiators	2 – 4 ft/s
	Main distribution headers	4 – 8 ft/s
	Max Recommended Velocity	≤ 4 ft/s (pipes ≤ 2”), ≤ 6 ft/s (pipes > 2”). Avoid >8 ft/s to prevent noise and water hammer

Advantages:

- Simple and quick to apply
- Helps prevent noise and pipe wear
- Useful for systems with short runs and few fittings

Disadvantages:

- Doesn't account for total pressure drop
- May lead to oversized pipes in long systems

Equation 10. Pipe Sizing on Velocity Criteria

$$Q = A \times v$$

Where:

- Q = Flowrate
- A = Area of pipe -----[$A = \frac{\pi D^2}{4}$ where $\pi = 3.14$ and D is diameter of pipe]
- v = velocity of fluid

Empirically, matching the units: $Q = 2.45 \times v \times (D_{\text{INCHES}})^2$

Where:



- Q is the volumetric flowrate of the fluid in gallons per minute (GPM)
- v is the desired velocity of the fluid in feet per second (fps). Keep under 6 fps.
- D is the internal diameter of the pipe in inches
- 2.45 is the conversion factor to get results in GPM, with pipe diameter in inches and velocity in feet per second (fps).

Equation 11. Estimating Flowrate (Q)

$$Q \text{ (GPM)} = \frac{\text{Boiler Output (Btu/h)}}{500 \times \Delta T}$$

Where: ΔT is the temperature differential between supply and return (°F)

Table 66. Heating Loads and the Flowrates

	ΔT (°F)	Heat Delivered per 1 GPM (Btu/h)
	20°F	10,000 Btu/h
	25°F	12,500 Btu/h
	30°F	15,000 Btu/h

Example: Calculating Flowrate

If your total heating load is 500,000 Btu/h, and ΔT is 25°F, you'd get the flowrate of 12,500 Btu/h.

$$Q = \frac{500,000 \text{ Btu/h}}{500 \times 25} = 40 \text{ GPM}$$

Example: Calculating Pipe Diameter

Determine the optimum diameter of pipe for allowing 40 GPM water flowrate at 4 fps velocity.



$$D = \sqrt{\frac{0.41 * Q}{v}}$$

$$D = \sqrt{\frac{0.41 * 40}{4}} = \sim 2 \text{ inches}$$

Pipe Sizing based on Pressure Drop (Friction Loss) Method

This method aims to limit pressure drop within 2–4 ft per 100 ft of piping. Friction loss is influenced by flow rate, pipe diameter, length, and material roughness. Choosing the right pipe size helps reduce friction losses, promoting uniform heat distribution and lowering pump energy use, especially in large or complex systems. It's important to cross-check both velocity and friction loss to stay within recommended limits.

Table 67. Allowable Pressure Drop

	Pipe Type	Friction Loss (ft head / 100 ft)
	Branch Circuits	1 – 3 ft/100 ft
	Main Distribution	3 – 4 ft/100 ft
	Max Recommended Limit	< 4 ft/100 ft (per ASHRAE & industry best practices)

Advantages:

- More accurate sizing, especially in large systems
- Ensures proper pump sizing and system balancing
- Help maintain target flow rates over long distances

Disadvantages:

- Requires more detailed calculation or software
- Not as intuitive as the velocity method

Friction Loss Calculations

Two common equations for estimating friction loss are using Darcy-Weisbach equation and Hazen-William's equation.

Equation 12. Darcy-Weisbach Equation

The head loss (hf) is expressed in feet of water column:

$$hf = f \times \left(\frac{L}{D}\right) \times \left(\frac{V^2}{2g}\right)$$

where f is the friction factor (dimensionless), L is the length of the pipe (feet), D is the diameter of the pipe (feet), V is the average fluid velocity (feet per second), and g is the acceleration due to gravity (32.2 ft/s²). The units of the right-hand side of the equation are feet of water column.

Equation 13. Hazen-William's Equation



The head loss (hf) is expressed in feet of water column:

$$hf = \left(\frac{4.26 \times Q^{1.85}}{C^{1.85}}\right) \times \left(\frac{D^{4.87}}{L}\right)$$

where Q is the flowrate (gallons per minute), D is the diameter of the pipe (inches), L is the length of the pipe (feet), and C is the Hazen-Williams coefficient (dimensionless).

Assume a value of C = 100 for old or dirty pipe (i.e., in open systems), 140 for new steel pipe, and 150 for plastic or copper tube/pipe.

Table 68. Recommendations for Friction Loss Method

	Equations	Key Points
	Darcy-Weisbach	Accurate; accounts for pipe roughness, fluid density, and viscosity. Best for detailed design.
	Hazen-Williams	Simpler; good for water flow in typical HVAC applications. Assumes constant roughness (C-factor).

Pipe Sizing Nomographs

Several charts and tables are available that aid designers in estimating friction losses for various pipe sizes, flowrates, and pipe materials. These charts are often based on empirical data and are useful for quickly estimating friction losses without performing complex calculations.

Pressure Loss Charts: Steel, Copper, PEX pipes

ASHRAE provides pressure loss data for steel, copper, and plastic pipes. Since internal bore diameter differs by material, it affects fluid velocity and friction loss. Always use flow and pressure drop charts specific to the pipe material for accurate sizing.

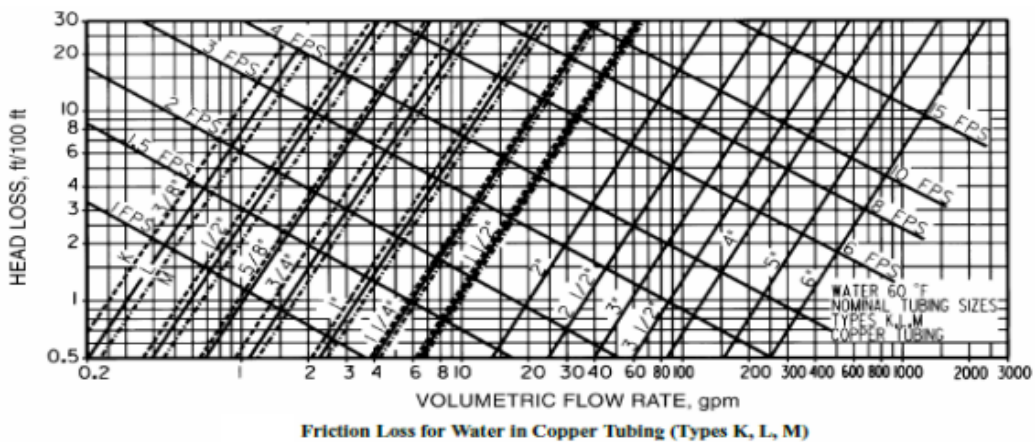
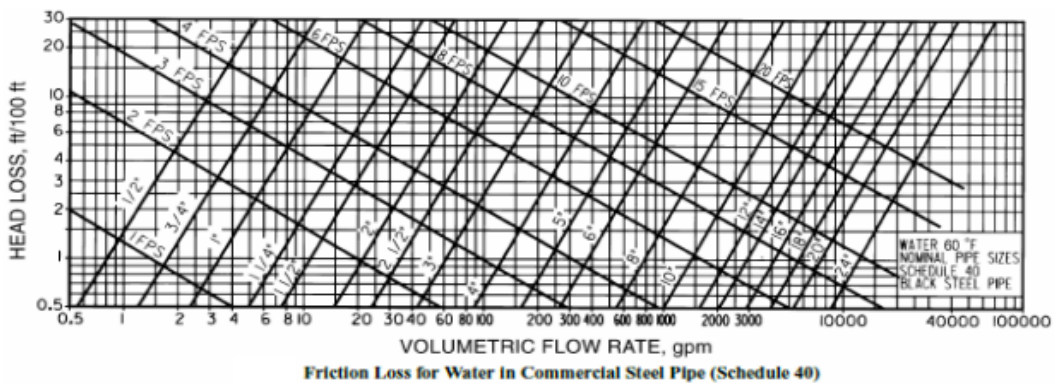

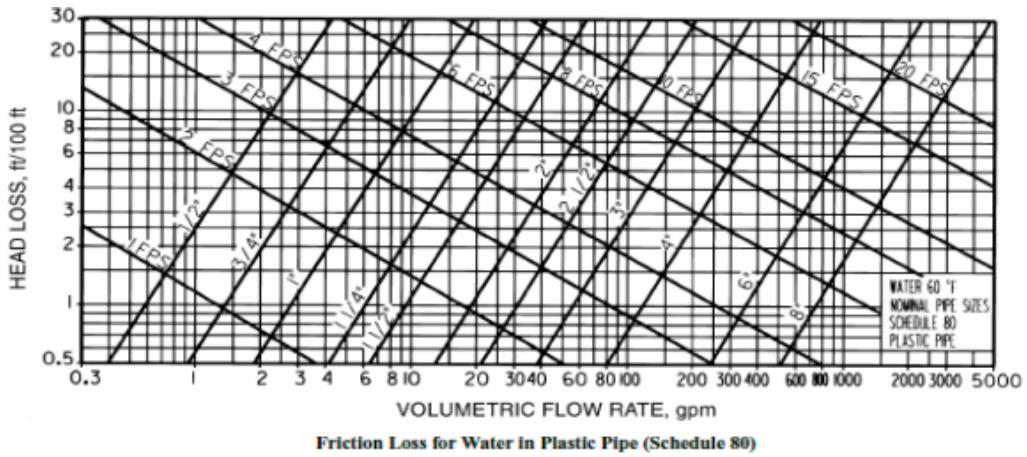

Example:

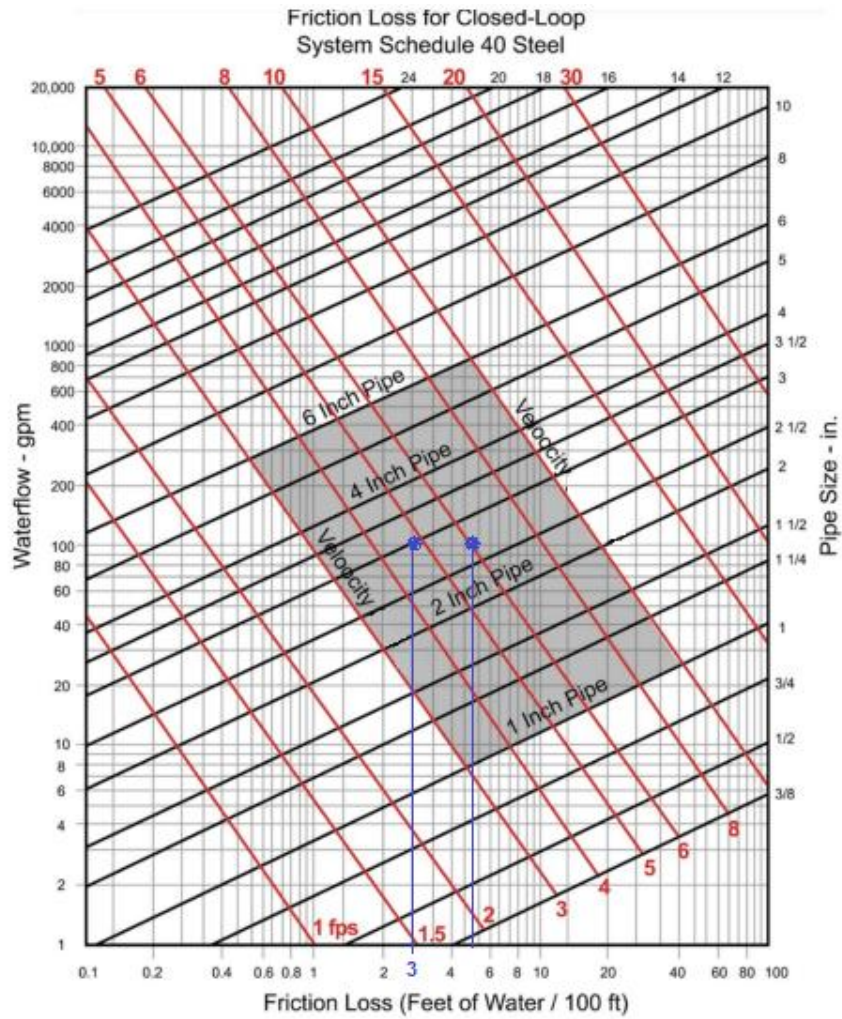

Figure 13. Nomograph for Carbon Steel Pipe Sizing

For a 100 GPM flowrate, a 3-inch pipe is recommended to meet the friction loss criteria of 4 ft/100 ft, with a velocity of about 5 fps, while a 2.5-inch pipe will satisfy the velocity criteria of 6 fps but have a higher friction loss of around 5 ft/100 ft.



When the flowrate (GPM) is known, you may select the pipe size from the table below, which also shows the velocity, and the pressure drop.

Table 69. Pipe Sizing Tables: Flowrates (GPM) at different Velocity and Pressure drop

Pipe Size (inches)	Velocity Criteria		Pressure Drop Criteria		
	Flow (GPM) @ 4 fps	Flow (GPM) @ 6 fps	Flow (GPM) @ 2 ft/100 ft	Flow (GPM) @ 3 ft/100 ft	Flow (GPM) @ 4 ft/100 ft
½"	3	,	1.1	1.3	1.5
¾"	7	,	2.4	3.0	3.4
1"	12	,	4.4	5.3	6.2
1¼"	17	,	7.1	8.7	10.1
1½"	24	,	10.8	13.2	15.3
2"	39	,	32.0	39.2	45.3
2½"	,	92	58	71	82
3"	,	132	92	113	131
4"	,	235	162	199	230
6"	,	530	368	452	522
8"	,	880	642	787	911
10"	,	1380	1015	1245	1440







Pipe Pressure Ratings and Thickness Standards

Selecting the appropriate hydronic piping schedule thickness involves identifying the design pressure, operating temperature, and applicable standards. The American Society of Mechanical Engineers (ASME) provides guidelines for carbon steel pipes.

	Selection Criteria	Key Considerations
	System Design Pressure	Select pipe material and schedule (e.g., Sch 40/80) rated for max system pressure.
	Operating Temperature	Use suitable material (e.g., steel for 800°F, PEX for ≤200°F) based on system temp.
	Hydrostatic Testing	Test at 1.5× design pressure per ASME/ASTM standards (e.g., ASME B31.1).

Choosing Pipe Schedule

Use the design pressure and temperature to select an appropriate pipe schedule from ASME B31.1 or ASME B31.9. The table below provides the pressure ratings for Schedule 40 and Schedule 80, ASTM A53 Carbon Steel pipes at various temperatures.

	Temperature (°F)	Pressure Ratings (psi) for ASTM A53 Carbon Steel Pipe	
		Schedule 40	Schedule 80
	100	285	400
	200	260	370
	300	230	340
	400	200	300
	500	170	270
	600	140	240
	650	125	225

Piping Design Configurations

The piping system can be designed as one-pipe or two-pipe system.

One-pipe series loop systems

A one-pipe system uses a single loop for both supply and return. As hot water moves through each radiator, it cools, so downstream radiators receive cooler water and must be oversized for equal heat output. Best suited for small residential applications.

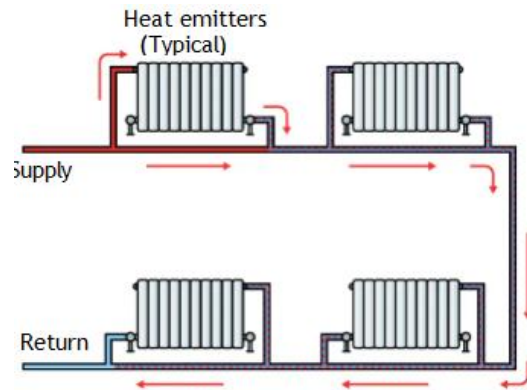

Figure 14. One Pipe System

Two-pipe system

A two-pipe system uses separate supply and return lines, delivering the same supply temperature to all emitters. Its costs more than one-pipe layouts but offer better performance, water travels shorter distances, returns faster to the boiler, and allows improved temperature control across zones.

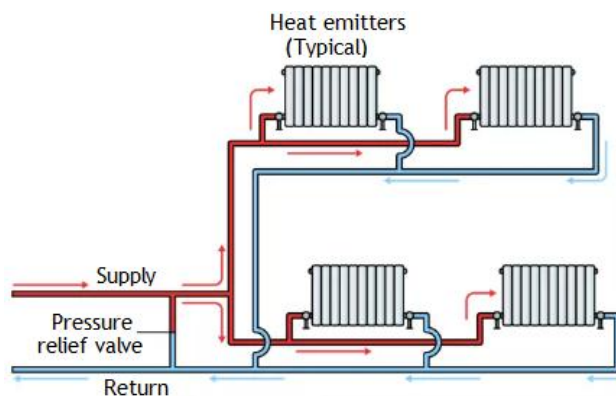

Figure 15. Two Pipe System

Two pipe system can be designed as direct return and reverse return systems. The difference is explained below.

1.1.16 Direct Return Layout

In a direct-return system, water flows to and from terminals in the same sequence, the first terminal supplied is also the first to return. Each emitter gets nearly the same water temperature, but flow rates differ due to varying pipe lengths. Emitters closer to the boiler (unit A in the figure below) have shorter path, and lower resistance, receiving more flow than those farther away (emitters B to F in the figure).

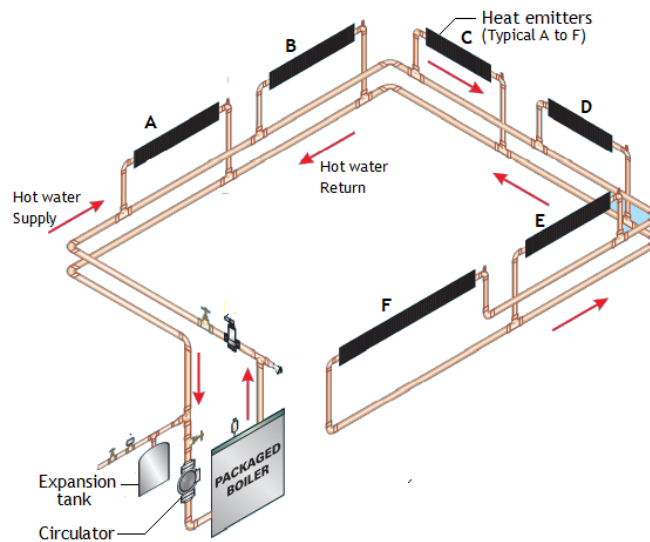









Figure 16. Two Pipe Direct Return System

Table 70. Direct Return Systems

	Characteristics	Rules of Thumb
	Piping Configuration	The first unit supplied is the first to return.
	Pressure Drop	Uneven pipe lengths cause variable pressure drops across branches.
	Flow Distribution	Closer emitters get more flow; distant ones get less.
	Balancing Requirement	Requires balancing valves on every branch; manual balancing needed.
	Piping Requirements	Less piping than reverse return.
	Installation Costs	Lower due to simpler layout.
	System Suitability	Best for systems with PICVs or balancing valves.

Reverse Return Layout

A reverse return system is a piping configuration designed to promote balanced flow distribution across multiple heat emitters, without relying heavily on manual balancing valves. Unlike a direct return system, where the first terminal unit on the supply line is also the first on the return line, a reverse return system routes the return piping so that the first unit supplied is the last to return. This ensures that the total pipe length from the boiler to each terminal unit and back is approximately the same. As a result, each unit sees similar pressure drops resulting in uniform flow rate distribution across all branches, reducing the need for extensive manual balancing. However, this setup requires additional piping, often referred to as the "third pipe," which increases installation costs and complexity, though it enhances system balance and efficiency, particularly in systems with constant flow rates.

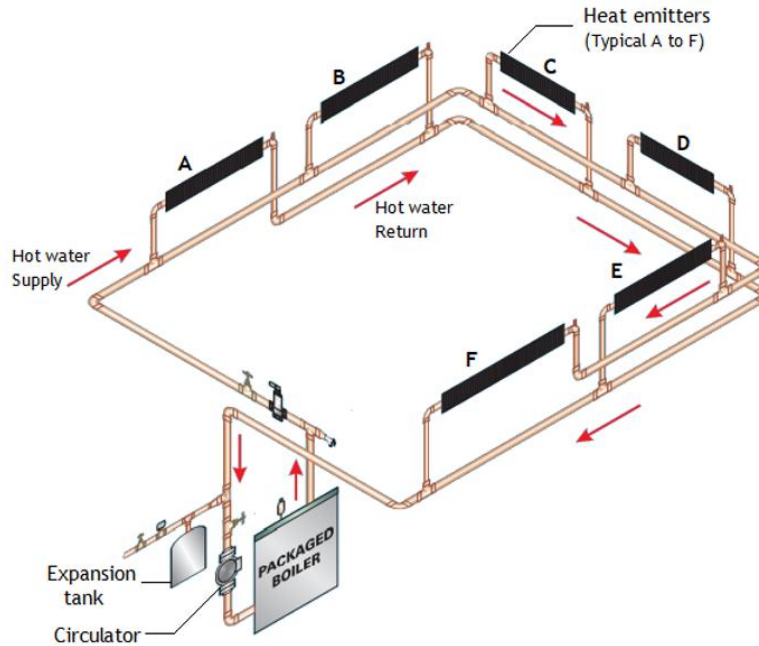









Figure 17. Two Pipe Reverse Return System

Table 71. Reverse Return System

	Characteristics	Rules of Thumb
	Flow Distribution	Promotes uniform and balanced flow to all terminal units.
	Piping Layout	The first unit supplied is the last to return.
	Piping Configuration	Equalizes supply + return length for each terminal.
	Pressure Drop	Similar pressure drops across all branches due to equal pipe lengths.
	Installation Costs	Higher due to extra return piping.
	System Tuning	Minimal balancing required.
	Benefits	Improves efficiency by reducing flow imbalance at terminals.

Note: Reverse return system may be less necessary in modern systems using pressure-independent control valves (PICVs).

Using Pressure-Independent Control Valves (PICVs)

The introduction of Pressure-Independent Control Valves (PICVs) has made reverse return piping largely redundant in modern hydronic hot water systems. PICVs combine a control valve with a differential pressure regulator, automatically maintaining a constant flow rate through each terminal unit regardless of system pressure fluctuations. This is achieved by adjusting the valve opening to compensate for changes in differential pressure, ensuring precise flow control without manual balancing.

In a direct return system equipped with PICVs, the valves dynamically balance the system, eliminating the need for equal pipe lengths or additional return piping characteristic of reverse return systems. PICVs also address issues like low delta T syndrome, where insufficient flow reduces heat transfer efficiency, by maintaining optimal flow rates. By using PICVs, designers can achieve self-balancing systems with lower installation costs, as the extra piping of reverse return systems becomes unnecessary. Additionally, PICVs support variable flow systems with variable-speed pumps, further enhancing energy efficiency by reducing pump head and power consumption. Thus, PICVs offer a simpler, more cost-effective alternative to reverse return systems while enhancing control and performance.

1.1.17 Two- Pipe Heating and Cooling Systems: A Hybrid Approach

A two-pipe system uses the same supply and return lines for either heating or cooling. It circulates hot water in winter and chilled water in summer. The system operates in either heating or cooling mode, but not at the same time.

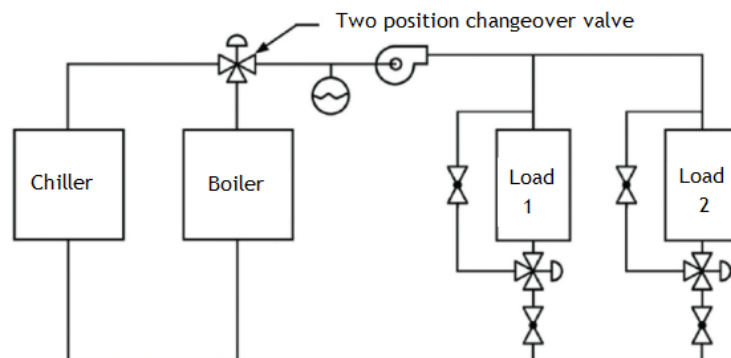

Figure 18. Two Pipe Hybrid System

1.1.18 4-Pipe System

A four-pipe heating and cooling system uses four pipes to distribute heat and cooling to various parts of a building. Two pipes are dedicated to heating, and two pipes are dedicated to cooling. This arrangement offers significantly more flexibility than two-pipe systems by providing simultaneous heating and cooling capabilities.

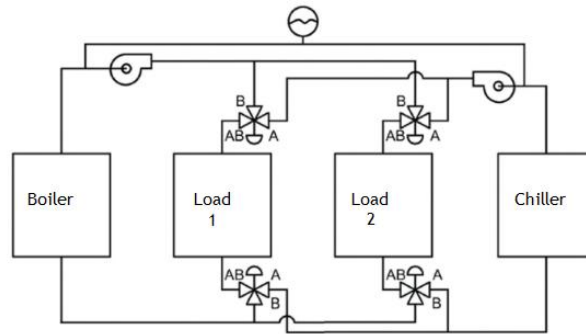

Figure 19. Four Pipe Hybrid System

Table 72. Comparison: Two-Pipe vs. Four-Pipe Hybrid Systems

	Feature	Two-Pipe System	Four-Pipe System
👍	Piping	2 pipes (1 supply + 1 return)	4 pipes (hot & chilled water supply/return)
👍	Functionality	Heating or cooling only	Simultaneous heating and cooling
👍	Changeover	Manual or scheduled (seasonal)	No changeover; automatic zone control
👍	Comfort Control	Limited in shoulder seasons	High; individual zone demands met
👍	Initial Cost	Lower	Higher (extra piping & controls)
👍	Operation Flexibility	Centralized switching	Independent zone control
👍	Energy Efficiency	Efficient in single-mode operation	May use more energy but optimizes comfort
👍	Maintenance	Lower; fewer components	Higher; more valves, piping, controls
👍	Applications	Uniform seasonal load buildings	Multi-zone, variable load buildings
👍	Codes & Standards	ASHRAE 90.1, IMC, local HVAC codes	ASHRAE 90.1, IMC, local HVAC codes
👍	Benchmark	Cost savings ~10-20% vs four-pipe in simple buildings	Better thermal comfort & zone control in complex systems

Primary Secondary Piping

The Primary-Secondary (P/S) piping arrangement consists of two loops: the primary loop connects the boiler to the system, and the secondary loop circulates water through terminal units. Each loop has its own pump, and they are hydraulically separated by a “decoupler” or “common pipe header” (zero pressure bridge). This separation allows different flow rates in each loop, higher in the system and lower through the boiler, improving control, efficiency, and temperature consistency. Under full load, all primary water serves the system, but most of the year it operates at part load, with only some primary water entering the secondary loop.

Benefits of P/S Piping

- a. Hydraulic Separation
- b. The flow of one circulator does not affect the flow of another circulator
- c. Guarantees the proper flow through the boiler not dependent on system flow
- d. Allows multiple Delta-Ts within the heating system. For instance, system could be one delta-T, and the boiler could be at a different Delta-T if required

The core of primary/secondary (P/S) systems is hydraulic separation, based on the principle that when two circuits are joined by a common pipe with zero pressure drop, flow in one circuit will not induce flow in the other. This is achieved by connecting the primary and secondary loops using two closely spaced tees, forming a short common pipe, known as the decoupler, that ensures hydraulic separation.

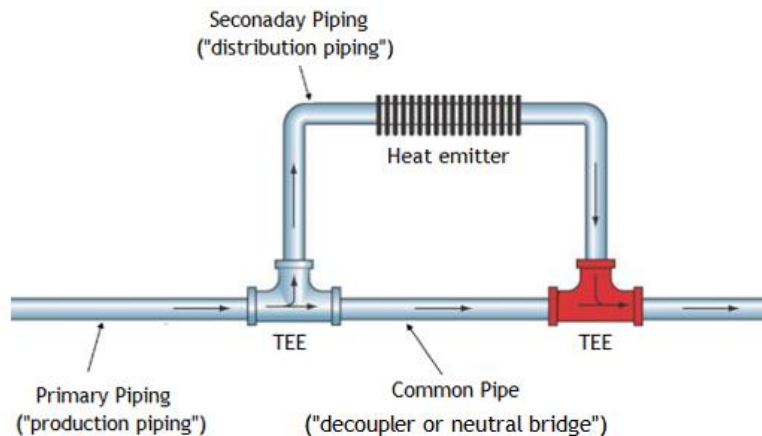

Primary-Secondary Distribution

The key feature of a primary/secondary piping system is the closely spaced tees, which must be no more than 12 inches apart or 4 times the pipe diameter, whichever is less. Additionally, the straight pipe extending from these tees should be at least 8 pipe diameters long (or 4 diameters for chilled water systems) to ensure proper hydraulic separation and flow stability.

The Law of Tee

The basic principle of a Tee is that the total flow entering must equal the total flow exiting through the remaining outlets. Water entering the tee at point A can either flow to point B (towards the heat emitter) or continue to point C along the main loop back to the boiler. This follows the equation:

$$\text{Flow at A} = \text{Flow at B} + \text{Flow at C}$$

For example, if 150 GPM enters at point A, a total of 150 GPM must exit, either entirely through one outlet or split between both in some combination equal to 150 GPM.

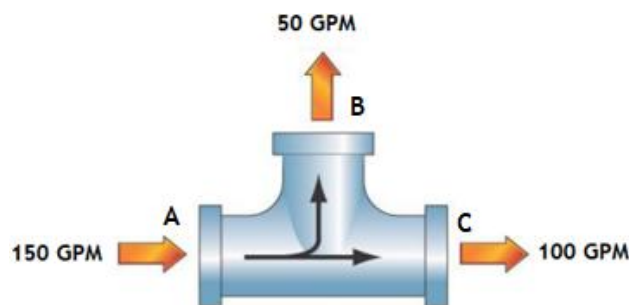
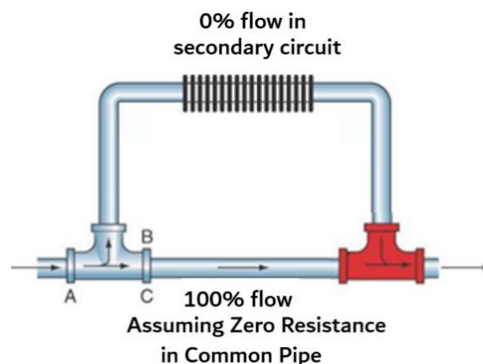
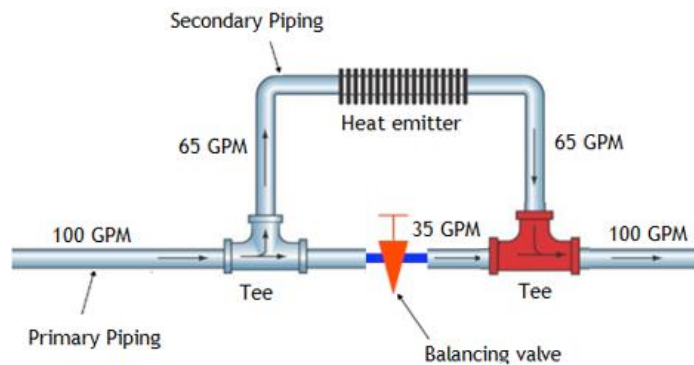

Figure 20. The Law of Tee

When two piping circuits are connected, flow in one will not induce flow in the other unless there is a pressure difference. If the common pipe between the two tees has no resistance, it becomes the path of least resistance, allowing all the flow to pass straight through. As a result, no flow occurs in the secondary loop, everything remains confined to the primary circuit.



Now, consider a 'balancing valve' added in the common pipe. This valve will introduce some resistance when throttled, causing flow to split. For example, of 100 GPM entering the tee, 35 GPM may continue through the common pipe while 65 GPM diverts to the secondary loop, maintaining the Tee principle: flow in equals flow out.



Pumps in Primary & Secondary Loops

In a primary-secondary system, pumps are required on both loops. The primary loop pump circulates water between the boiler and low loss header, sized only for primary loop piping. The secondary loop pump overcomes frictional resistance in the building's piping and terminal units, sized only for secondary loop piping. If the secondary pump has a higher capacity than the primary, say, 150 GPM while the primary supplies only 100 GPM, the system becomes unbalanced. Since flow out of a Tee can't exceed flow in, the extra 50 GPM must be made up somehow.

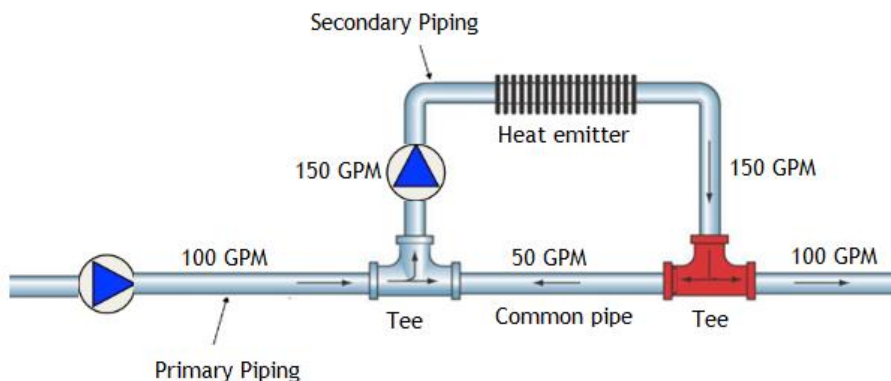

So, where do the remaining 50 GPM come from? It comes from the common pipe, creating a reverse flow condition, 100 GPM from the primary and 50 GPM drawn by the secondary pump. This causes both pumps to work against each other, leading to unstable flow, temperature imbalance, and system performance issues. Although undesirable, this scenario still follows the Tee Law, where inflow must equal outflow, highlighting the law's validity even in reverse flow situations.

Heating systems can be designed with constant flow (regulated by temperature) or variable flow (regulated by pump speed).

1.1.19 Primary and Secondary Loop Pumps

In heating systems, the primary circuit typically uses constant-speed pumps to maintain constant flow, with temperature regulation used to control heating output. These pumps are designed for maximum flow. Modern variable flow primary pump systems are getting increasingly popular due to their lower installation cost (fewer pipes, pumps, and valves) and improved energy efficiency. However, they add complexity in bypass design and require advanced controls to ensure minimum flow through the boiler.

Secondary circuits may use either constant or variable-speed pumps, with variable-speed options offering better energy efficiency and demand-based control.

Multiple-Emitters

In practice, the building heating system shall include multiple emitters connected to one main piping loop that connects the supply of the boiler back to the boiler's return. Each terminal unit is connected to the main supply loop. Uses two tees for each terminal.

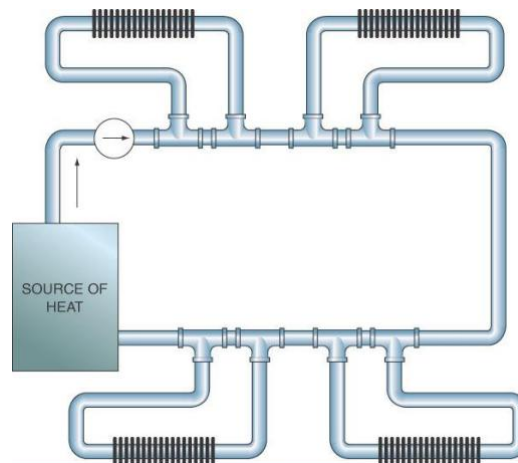

Summarizing the functioning of common pipe,

Rule#1: What enters the tee must equal what exits: Inlet flow = Sum of outlet flows.

Rule#2: Flow direction through tees is governed by pressure differences, not fixed paths.

Rule#3: Keep the common pipe in a primary-secondary system as short as possible to ensure effective hydraulic separation. Longer runs add resistance and compromise performance.

Rule#4: One of the following three scenarios will always occur:

- Primary Flow > Secondary Flow, the flow direction in common pipe will be towards right.
- Primary Flow < Secondary Flow, the flow direction in common pipe will reverse to left direction.
- Primary Flow = Secondary Flow, there will be no flow in the common pipe.

See the figure below for correct Tee placement.

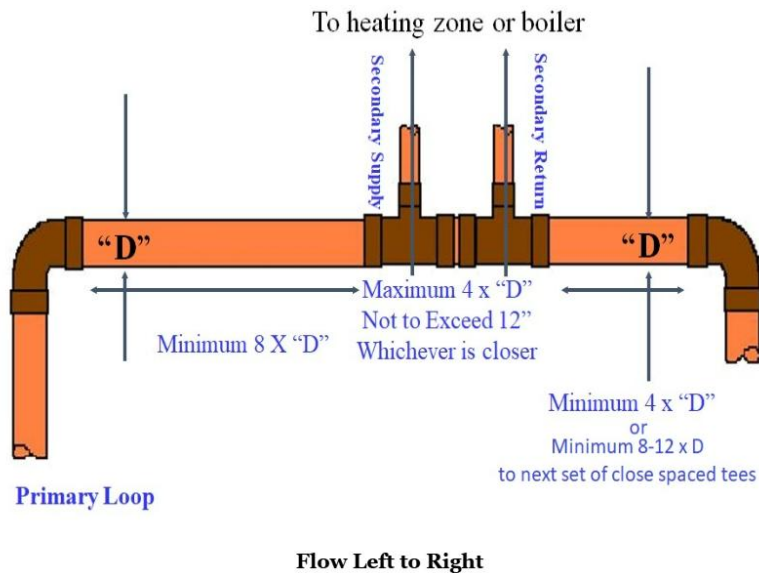











Table 73. Design Rules for Primary-Secondary Piping Configuration

	Design Factor / Condition	Rules of Thumb
	Primary Loop Sizing	Constant flow; size piping for boiler max output.
	Secondary Loop Sizing	Variable-speed circulators; size by zone load for energy efficiency.
	Hydraulic Separation (Common Pipe)	Minimize pressure drop to avoid ghost flow. Use large diameter pipe equal or larger than primary loop. Use closely spaced tees $\leq 12"$ (max $4\times$ pipe dia.), standard TEEs only. No valves/fittings between TEEs. Use low-loss header if multiple circuits.
	Spacing Between Tees	$4\times$ pipe diameter, not exceeding 12". TEEs spacing (if the terminal unit is above the main hot water loop) Bell & Gossett: 6" min; Taco: 12" min.
	Straight Pipe Length (before/after tees)	Hot water: $\geq 8\times$ pipe diameter; Chilled water: $\geq 4\times$ pipe diameter.
	Spacing Between Multiple Tee Sets	8–12 pipe diameters apart.
	Flow Direction	Primary flow runs through TEE run; secondary flow through branch (bull).
	Flow Control Valves	Use weighted check valves or flow control valves to prevent unwanted gravity flow.
	Velocity in Common Pipe	≤ 1 fps to maintain smooth loop-back and hydraulic separation.
	Code References	ASHRAE 90.1, IMC, Bell & Gossett and Taco design manuals, local HVAC codes.

Piping Accessories (Valves)

Hot water hydronic systems rely on various valves and piping accessories to ensure efficient flow control, safety, and maintenance. Key components include:

- a. Isolation Valves: Allow system shut-off for maintenance or zone control; typically, ball or gate type.
- b. Balancing Valves: Manually adjusted to ensure even flow across branch circuits.
- c. Check Valves: Prevent reverse flow and maintain unidirectional circulation.
- d. Flow Control Valves: Act as flow check valves to block unwanted circulation when a loop is inactive.
- e. Air Vents & Separators: Eliminate trapped air, improving system efficiency and preventing air locks.
- f. Pressure Reducing Valves: Automatically regulate fill water pressure (typically ~15 psig) to match system design; installed at the point of no pressure change.
- g. Pressure Relief Valves: Mandatory A.S.M.E.-rated safety valves that relieve pressure if it exceeds design limits (commonly set at 30 psig). Must be installed vertically without any shut-off valves between boiler and relief discharge.
- h. Drain Valves: Enable safe draining or flushing of the system.
- i. Thermostatic Mixing Valves: Mix hot and cold water to control outlet temperature for comfort and scald protection.
- j. Zone Valves: Enable temperature zoning; open/close based on thermostat signals and activate the circulator via end switches.
- k. Flow Meters: Monitor flow rates for commissioning, diagnostics, and system balancing.







Expansion Tanks

In closed-loop hydronic systems, the expansion tank is essential for managing system pressure as water heats and expands. It absorbs excess volume to prevent overpressure and equipment damage. Modern tanks use a diaphragm or bladder to separate air and water, maintaining consistent pressure. The tank is connected at the “no pressure change point”, the one location unaffected by pump pressure. This is the only point in the system where the pump cannot affect the pressure, and the pressure will always be the same. System pressure at this point is influenced only by adding or removing water, adjusting the tank’s air charge, or thermal expansion of water.

Key rule: always pump away from the expansion tank. This raises system pressure, improves air control, and avoids air release issues caused by low pressure at the pump inlet. Pumping toward

the tank reduces pressure, which can release dissolved air as bubbles, leading to noise and circulation issues.





Table 74. Expansion Tank Design

	Description	Rules of Thumb
	Expansion Volume	Water expands ~3.7% per 140°F rise (e.g., 60°F to 200°F).
	Tank Sizing	Size for total system volume; assume ~4% expansion volume.
	Tank Type	Use closed bladder/diaphragm tanks; monitor for bladder failure (avoid waterlogging).
	Relief Valve Protection	Tank must absorb expansion to prevent relief valve discharge (set ~30 psi).
	Pressure Settings	Set tank air pre-charge pressure close to system static fill pressure (12–15 psi).
	Circulator Protection	Proper sizing/placement prevents pressure swings affecting circulator operation.
	Installation Location	Install on circulator suction side (near boiler) for pressure stability and noise control.

Estimate System Volume for Expansion Tank Sizing

The volume of water in the loop (also called system water volume) and the difference between the maximum and minimum operating temperatures determine the expansion tank size. Generally, the required volume is less than 10% of the system volume. Use the following guidelines to estimate the system volume.

Table 75. System Volume for Heating Equipment

	Heating Equipment	Gallons per 10,000 Btu/h @ 200°F
	Boiler Volume	1.0 gallon per 4,300 Btu/h output (typical)
	Cast Iron Convactor	1.5 gallons
	Cast Iron Baseboard	4.7 gallons
	Nonferrous Convactor	0.64 gallons
	Nonferrous Baseboard (¾")	0.37 gallons

	Heating Equipment	Gallons per 10,000 Btu/h @ 200°F
	Fan Coil / Unit Heater	0.2 gallons

Table 76. System Volume in Piping













	Pipe size (inches)	Gallons per running foot
	½"	0.016
	¾"	0.028
	1"	0.045
	1¼"	0.078
	1½"	0.106
	2"	0.17
	2½"	0.25
	3"	0.38
	4"	0.66
	6"	1.5

Table 77. Estimated System Volume – Rules of Thumb

	Method	Rules of Thumb / Example
	Based on Boiler Output	System Volume (gal) = (Btu/h ÷ 10,000) × 4 Example: 50,000 Btu/h → 20 gal
	Based on Circulating Pump Flow	System Volume (gal) = Pump Flow (GPM) × 3 Example: 15 GPM → 45 gal.

Air in Hydronic Heating Systems

Air is a major concern in hydronic heating systems and must be effectively removed to maintain proper operation, system efficiency, prevent corrosion, and ensure long-term reliability. This is achieved through air separators and other air elimination devices.









Air Separators

Air separators are devices used to remove air and gases from hydronic systems. Since air is less dense than water, it naturally rises. Air separators are designed with a larger internal chamber to slow down water flow, allowing air bubbles to rise and collect. The trapped air is then released through a manual or automatic vent.

Common Types of Air Separators:

- a. Centrifugal Separators: Use spinning motion to separate and vent air from circulating water.
- b. Tangential Separators: Introduce water tangentially to create a vortex that drives air out.
- c. Coalescing Separators: Use internal media (baffles, mesh, rings) to merge small air bubbles into larger ones for easier removal.

Table 78. Air Elimination Devices

	Devices	Function/Rules of Thumb
	Manual Air Vents	Installed at high points; manually opened to release air (coin vents).
	Automatic Air Vents	Automatically release air; common on radiators and risers.
	Float-Type Air Vents	Float closes valve with water; opens to vent trapped air.
	Fiber Disc Type Vents	Discs swell when wet (close), shrink when dry (vent air).
	Micro-Bubble Separators	Use mesh/media to capture tiny air bubbles for better removal.
	Air Scoops	Baffles deflect/collect air; older but still used design.
	High Point Vents	At top of vertical pipes to vent naturally rising air.
	Air Pergers	Temporary devices used during filling/startup for large air removal.

Insulation

Pipe insulation minimizes heat loss and ensures efficient heat delivery to occupied spaces. Pipes in unheated areas like crawlspaces should be insulated, typically with molded fiberglass. Pumps and valves are commonly insulated to the same level as the piping using a fabricated-box approach or with removable/reusable covers to facilitate maintenance.

Common insulation types in hydronic systems include:

- a. Mineral fiber (fiberglass, mineral wool) with all-service jackets, widely used for hot and cold piping.
- b. Flexible elastomeric and polyolefin, jacket-free and common in many systems.
- c. Rigid types like polyisocyanurate, phenolic, polystyrene, and cellular glass, used for high-performance applications.

Table 79. Minimum Piping Insulation

Fluid Operating Temperature Range (°F)	Insulation Conductivity		Nominal Pipe or Tube Size, in.				
	Conductivity* Btu-in/h.ft ² . °F	Mean Rating Temp., °F	<1	1 to <1-1/2	1-1/2 to <4	4 to <8	≥8
>350	0.32 to 0.34	250	4.5	5.0	5.0	5.0	5.0
251 to 350	0.29 to 0.32	200	3.0	4.0	4.5	4.5	4.5
201 to 250	0.27 to 0.30	150	2.5	2.5	2.5	3.0	3.0
141 to 200	0.25 to 0.29	125	1.5	1.5	2.0	2.0	2.0
105 to 140	0.22 to 0.28	100	1.0	1.0	1.5	1.5	1.5

Source: ASHRAE 90.1, 2019. Refer Table 6.8.3-1 for more details.

Note*: The conductivity values are typical of fiberglass and most elastomeric foam insulation, which are the most used insulation materials. The table shows the insulation thickness required depending on the pipe operating temperature and the size of the pipe. In general, hot pipes require anywhere from 1" to 5" of insulation depending on size and temperature.

Heating Emitters (Terminal Units)

Finned tube radiators, convectors, finned coils in central air-handling units, unit heaters, fan-coil units, and radiant floor heating systems are among the terminal units used in hydronic systems.

1.1.20 Radiators

Radiators are space-heating devices that emit heat primarily through a combination of radiation and convection. They operate by circulating hot water or steam through internal channels, transferring heat to the surrounding air and nearby surfaces. Commonly positioned beneath windows, radiators help neutralize cold drafts and promote uniform heat distribution within the room.



STEAM RADIATOR



HOT WATER RADIATOR



CAST IRON RADIATOR



PANEL RADIATOR









BASEBOARD RADIATOR



TOWEL RADIATOR

Proper radiator sizing requires aligning the unit's heat output (in Btu/h or Watts) with the calculated heat loss of the space, which depends on factors such as insulation quality, window area, and target indoor temperature. The radiator's construction material, surface area, and thermal inertia also influence its efficiency and responsiveness. The actual heat output depends on the interaction of several key parameters:

Table 80. Radiator Output Ratings – What Affects Them?

	Factors	Rules of Thumb
	Water Temperature	Higher temp = more output; Standard: 180°F supply / 160°F return, $\Delta T=20^{\circ}\text{F}$
	Design Room Temp	Cooler room → more heat transfer; Standard comfort: 68–72°F (use 70°F baseline)
	Water Flow Rate	Low flow reduces output; 1 GPM \approx 10,000 Btu/h @ $\Delta T=20^{\circ}\text{F}$; balance flow in multi-radiator circuits
	Size / Surface Area	Larger surface = higher output; longer/taller radiators increase capacity
	Material	Thermal inertia & responsiveness varies; Cast iron = slow/steady, Aluminum = fast heat-up
	Radiator Type	Output varies by type: Single panel 250–350 Btu/h/ft ² , Double panel 400–500, Convactor 500–700
	Radiator Size	Use manufacturer charts; output ranking: Type 33 > 22 > 21 > 10

Notes:









The Type 10, 21, 22, 33 radiator classifications are industry de facto standard in heating design and specification. They are widely used by radiator manufacturers and HVAC professionals to describe radiator panels and fin configurations. The system helps standardize how radiator heat output is specified and compared.

- Type 10: Single panel, no convactor fins (flat panel)
- Type 21: Single panel with one row of convactor fins
- Type 22: Double panel with one row of convactor fins
- Type 33: Triple panel with three rows of convactor fins
- More panels and fins = greater surface area and higher heat output.

So, Type 33 radiators produce the most heat, while Type 10 produces the least among these types.

Radiators are also classified according to material type, i.e., cast iron, radiators, steel radiators and aluminum radiators.

Table 81. Radiator Classification – Cast Iron, Steel and Aluminum Types

	Features	Cast Iron Radiators	Steel Radiators	Aluminum Radiators
	Material	Cast Iron	Stamped Steel Panels or Tubes	Extruded or Die-Cast Aluminum
	Construction	Sectional, custom lengths	Compact units, fixed panel/tube lengths	Modular sections
	Heat Output at 180°F supply / 160°F return, 70°F room temp.	100–150 Btu/h per section (180/160°F)	1,000–8,000+ Btu/h per unit	90–120 Btu/h per section
	Thermal Inertia	High (retains heat longer)	Low to Medium	Low (quick response)
	Corrosion Resistance	Excellent	Fair (needs coating)	Moderate
	Cost	\$\$\$ (High)	\$ (Low)	\$\$ (Moderate)
	Noise Level	Very Quiet	Quiet	Quiet
	Installation	Heavy, brittle, careful handling	Lightweight, easy mounting	Lightweight, modular
	Applications	Heritage homes, radiant comfort	Budget installations, low wall space	Modern systems, fast zoning

Notes

Total radiator capacity = number of sections × Btu/h per section.

Installation: 4 to 6 inches above floor and 2 to 3 inches from walls.

Radiator Sizing

Radiator size is typically measured in terms of its heat output, expressed in Btu/h or watts. To determine the correct radiator size and how many radiators you need, follow these steps:

- a. **Room Heat Loss Calculation:** Determine the room's heat loss in Btu/h using a heat loss calculator or manual calculation methods.
- b. **Radiator Selection:** Divide the total room heat loss by the Btu/h per section value to determine the number of sections required. For example, if a room requires 6,000 BTU/h and you're using a radiator with 300 Btu/h per section: $6,000 \text{ BTU/h} \div 300 \text{ BTU/h per section} = 20 \text{ sections}$
- c. **Adjust for Aesthetics and Space:** Consider the physical space available and aesthetic preferences. Taller radiators with fewer sections can provide the same output as shorter radiators with more sections.

If you can't find one that matches exactly, go for one that is slightly higher – the heating can always be turned down if it gives out too much heat.

1.1.21 Convectors

Convectors are space-heating devices that primarily transfer heat through convection rather than radiation. They operate by circulating hot water or steam through finned tubing, which heats the surrounding air. The heated air rises naturally or is assisted by a fan, creating a convection current that warms the space efficiently. Convectors are typically compact, lightweight, and can be installed along walls or within enclosures such as cabinets or recessed units.

Unlike radiators, which emit a significant portion of heat through radiation to nearby surfaces, convectors rely almost entirely on moving air to distribute heat, making them faster in response but less effective at providing radiant comfort. Because of their lower thermal mass and higher surface area due to fins, convectors heat up and cool down more quickly than radiators, allowing for tighter temperature control and energy savings in intermittent heating applications.

Table 82. Convectors Sizing Factors















	Factors	Rules of Thumb
	Design Water Temperature (ΔT)	180°F supply / 160°F return ($\Delta T = 20^\circ F$) is standard. Low-temp systems (e.g., 140°F/120°F) require larger convectors. (ASHRAE HVAC Systems and Equipment Handbook)
	Water Flow Rate	1 GPM \approx 10,000 Btu/h @ $\Delta T = 20^\circ F$. (ASHRAE Fundamentals)
	Design Room Temperature	Use 70°F as the baseline. Comfort range: 68°F–72°F. (ANSI/ASHRAE Standard 55)
	Fin Surface Area (Coil Design)	4–6 fins per inch typical. More fins = higher output. (Manufacturer Specs: Slant/Fin, Sterling)
	Convector Type	Natural convection: 150–300 Btu/h/ft. Fan-assisted: 400–800 Btu/h/ft. (ASHRAE Systems Manual)
	Material	Copper tubes with aluminum fins = standard for high conductivity. (Industry standard practice)
	Placement	Mount below windows to counteract drafts. Maintain $\geq 2''$ below and $\geq 1''$ above for airflow. (ASHRAE Fundamentals/SMACNA Duct Design Manual)
	Length & Size Selection	Select length to meet required Btu/h at design temp. Common sizes: 2'–10' long, 4"–10" high. (Manufacturer sizing charts)
	Flow Arrangement	One-pipe for small systems; two-pipe preferred in larger/multi-zone systems for better control. (ASHRAE HVAC Handbook)

Table 83. Types of Convectors for Space Heating

	Type	Rules of Thumb (Typical Output and Key Features)
	Natural Convection Convectors	150–300 Btu/h/ft – Passive airflow; silent & energy-efficient. Best under windows in long runs. Needs more length.
	Fan-Assisted Convectors	400–800 Btu/h/ft – Built-in fans for faster heat-up, compact sizing. Ideal for intermittent heating.
	Floor Convectors	200–600 Btu/h/ft – Recessed near glazing; prevents downdrafts. Great for aesthetic or architectural use.
	Wall-Mounted Convectors	200–400 Btu/h/ft – Base-of-wall units; common in perimeter zones. Clean wall space, widely used in schools/offices.
	Cabinet Unit Heaters (CUH)	1,000–5,000+ Btu/h/unit – Fan & thermostat-controlled, rugged. Fast recovery, suits entrances, warehouses.
	Baseboard Convectors	500–750 Btu/h/ft – Copper-aluminum fin tube; low profile. Simple install along walls. Standard in residential zones.

Notes: The capacity of a convector is commonly measured in Btu/h per linear foot (Btu/h/linear ft.) for most types, especially natural convection and baseboard convectors. However, for fan-assisted and cabinet-style convectors, it may also be expressed as total Btu/h per unit or Btu/ per square foot of surface area depending on the manufacturer and the application.

1.1.22 Fan Coil Units (FCUs)

Fan Coil Units (FCUs) are terminal HVAC devices used for space heating (and cooling). They circulate room air through a coil, which is heated by hot water or electric strip heater. The heated air is then blown back into the space by the fan, providing fast and controlled heating. FCUs are versatile, can be ducted or free-blowing, and can be installed horizontally (ceiling-mounted) or vertically (floor-mounted).

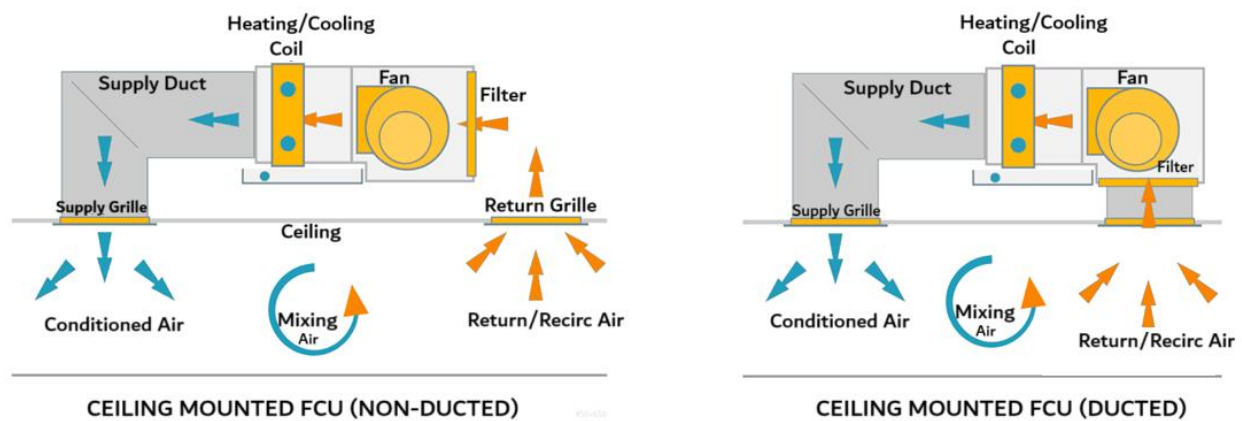

The effectiveness of a fan coil to heat depends on the surface area, size of heat exchanger, spacing and thickness of coil fins, the number of tubes and the performance of the fan. The temperature of the entering water as well as the temperature of the entering air will also influence the heat capacity of the fan-coil. The heat output of the fan coil is approximately proportional to the difference between the entering water temperature and the entering air temperature.

Table 84. Design Factors for Fan Coil Units









	Design Factor	Rules of Thumb
	Heating Capacity	200–1,200 Btu/h per ft ² (depends on space type and insulation)
	Entering Water Temp (EWT)	160–180°F for hot water coils
	Leaving Water Temp (LWT)	130–150°F; typical $\Delta T = 20\text{--}30^\circ\text{F}$
	Air Flow	200–1,200 CFM per unit; choose free-blow or ducted based on room layout
	Water Flow	~1.0 GPM per 10,000 Btu/h @ $\Delta T = 20^\circ\text{F}$
	Piping System	2-pipe: seasonal changeover; 4-pipe: simultaneous heat & cool
	Sound Level	≤ 40 dB(A) for quiet zones (hotels), ≤ 50 dB(A) for offices (per ASHRAE 170)
	Unit Mounting	Floor-mounted, wall-mounted, or concealed in ceilings; allow service access

Table 85. Types of Fan Coil Units





	FCU Type	Rules of Thumb (Capacity / Airflow / Features)
	Ceiling Exposed	5,000–15,000 Btu/h, 400–1,200 CFM. Visible unit, fast response, louder. Used in offices, retail, open spaces.
	Ceiling Concealed	4,000–12,000 Btu/h, 300–1,000 CFM. Quiet, ducted units, need a return plenum. Ideal for hotels, high-end offices.
	Floor-mounted	3,000–10,000 Btu/h, 200–800 CFM. Low-noise, perimeter use, minimal ductwork. Common in hotels, corridors, homes.
	High-wall FCUs	2,000–8,000 Btu/h, 200–600 CFM. Mini-split look, ideal for retrofits/modular spaces.
	Cassette Type	6,000–20,000 Btu/h, 400–1,200 CFM. 360° air throw, mounted in ceiling grid. Used in open offices, meeting rooms.



Figure 21. Types of Fan Coil Units

1.1.23 Unit Heaters

Unit heaters are forced convection heat emitters commonly used due to their low cost, quick temperature response, ease of installation, and compatibility with ventilation and waste heat systems. They also aid air circulation and can help with snow load protection for improved solar gain.

They come in two types based on airflow direction:

- a. Horizontal (Wall) Heaters – Ideal for low-height spaces; feature adjustable louvers.
- b. Vertical (Suspended) Heaters – Suitable for high ceilings, up to 75 feet.

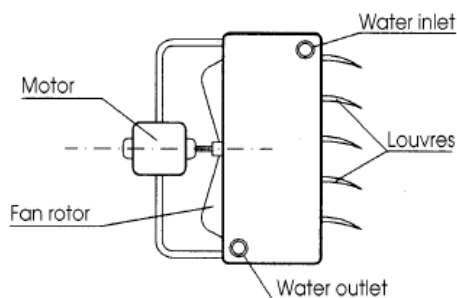

Horizontal Unit Heater

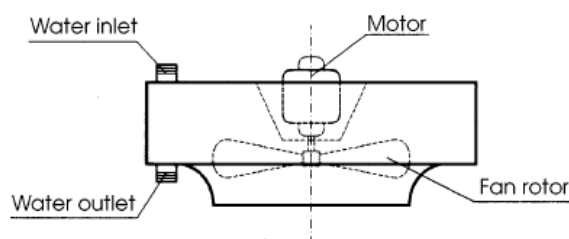

Vertical Unit Heater

Unit heaters are widely used in a variety of commercial, industrial, and utility spaces where quick, effective heating and air circulation are needed. Typical applications include:

- Warehouses & Storage Facilities – For even heat distribution in large open areas.
- Workshops & Garages – Quick heat-up and easy wall/ceiling mounting.
- Gymnasiums & Sports Arenas – Efficient space heating with minimal floor space use.
- Greenhouses – Maintaining controlled temperature and aiding plant growth.
- Factories & Manufacturing Plants – Integration with ventilation and waste heat systems.
- Aircraft Hangars – Vertical units handle tall spaces with high ceilings.
- Loading Docks – Prevents cold air infiltration during frequent door operation.
- Retail Backrooms & Utility Rooms – Inexpensive and flexible heating solution.

Installation of Unit Heaters

Some examples of effective installations are given below.

The horizontal unit heaters are arranged in such a way as to provide continuous movement of air along the external walls. This arrangement should be used in low, regularly shaped areas.

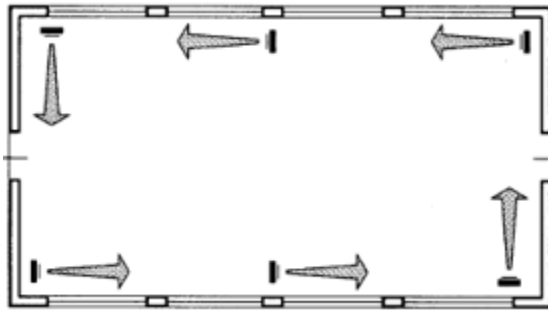

The horizontal unit heaters are installed along the main axis of symmetry of the area and their air outlets are directed towards the external walls. This arrangement should be used to heat particularly wide premises.

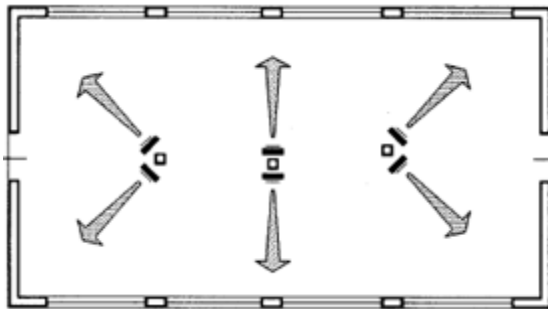

The horizontal unit heaters are installed on the external walls and their air outlets are directed towards the adjacent or opposite walls. This arrangement should be used in premises which are not very wide.

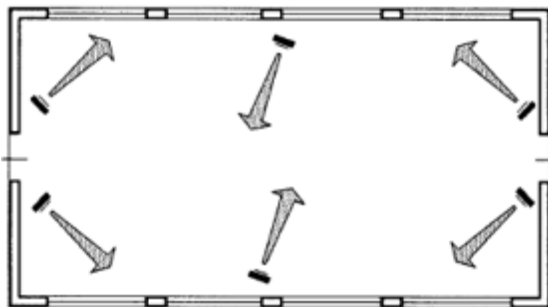

The vertical unit heaters are arranged with their air flows overlapping each other. This arrangement should be used on premises with heights of more than 15 ft.

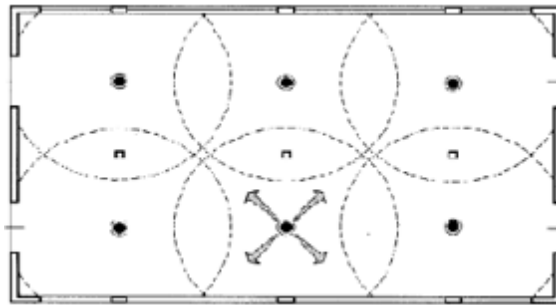

Summarizing different types of heat emitters....

Table 86. Heat Emitter Sizing and Selection Criteria

	Characteristic	Radiators	Convectors	Unit Heaters	Fan Coil Units (FCUs)
👍	Heat Transfer	Radiation + Natural Convection	Natural or Fan-assisted Convection	Forced Convection (Fan)	Forced Convection (Fan)
👍	Capacity	200–600 Btu/h/ft	300–1,000 Btu/h/ft	10,000–150,000 Btu/h	2,000–20,000 Btu/h
👍	Air Movement	Passive	Minimal to Moderate	Moderate to High	Active (Fan Driven)
👍	Control	Slow, Manual/TRVs	Moderate Response	Fast Response	Fast, Thermostat-Controlled
👍	Applications	Homes, Offices, Heritage	Offices, Schools, Baseboards	Garages, Warehouses	Hotels, Hospitals, Apartments
👍	Integration	Standalone	Standalone	Standalone	Integrates with HVAC

Table 87. Pipe Sizing per Emitter Loop

Size pipes based on flow rate, velocity, and convector total Btu/h load requirements.









	Pipe Size	Max. No. of Convectors	Typical Flow Rate
	1/2"	Up to 3 units	Up to 1.5 GPM
	3/4"	Up to 8 units	Up to 4 GPM
	1"	10–16 units	Up to 8 GPM

Table 88. Installation Criteria for Heat Emitters

	Installation Criteria	Rules of Thumb
	Clearance	≥ 2" below convector for airflow; keep fins unobstructed.
	Placement Guidelines	Install under windows to offset cold drafts; avoid drapes/furniture interference.
	Mounting Height	Typically, 4"–6" above finished floor.
	Convector Spacing	Space 3–6 ft apart for even heat distribution.
	Convector Placement	Position near cold surfaces (windows/doors) for effective heating.

Space Temperature Control Strategies

In hydronic systems, temperature control often begins at the zone level, where each room or area has its own thermostat. These thermostats activate automatic zone control valves, which open or close based on the space temperature. When any zone calls for heat, its valve opens, prompting the circulator pump to start. The pump may run continuously with valves adjusting flow as needed, or it can be activated only when heating is required, via a thermostat or aquastat. To enhance efficiency and comfort, circulators may feature three-speed or variable-speed drives, allowing for optimal flow control based on system demand.

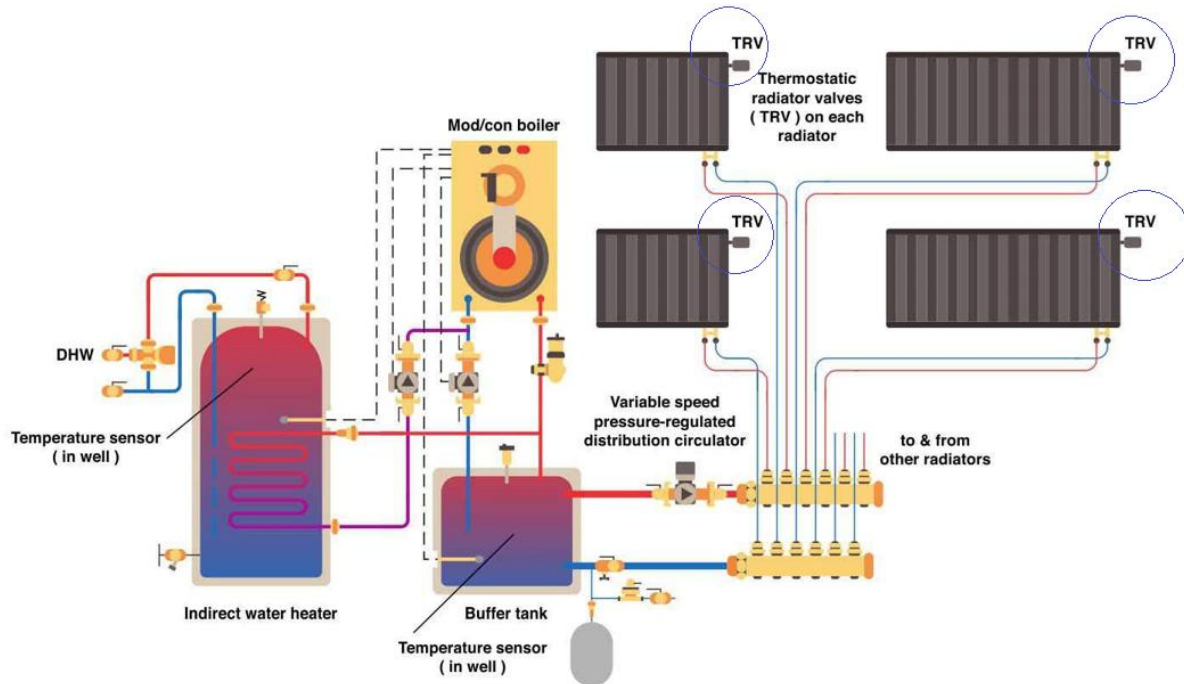

Figure 22. Hydronic Heating System Schematic

All plumbed heat emitters need radiator valves to work because they control the heat output of the radiator. The most common type of radiator valves are Thermostatic Radiator valves (TRVs) and Lock-shield Radiator valves.

- a. **Thermostatic Radiator Valves (TRVs):** TRVs contain a thermostat that measures the temperature in the room. So instead of only turning the radiator off or on, you can control the temperature on each radiator individually.
- b. **Lock-shield Radiator Valves:** Lock-shield radiator valves connect to the radiator and control the amount of water that flows out of the radiator and into the return pipework. It also allows the radiator to be “balanced”, meaning that the water is evenly distributed across the property ensuring that all the radiators heat up at the same time.

Beyond zone-level controls, there are four common strategies used to manage boiler operation and maximize energy efficiency:

Integrated Thermostat Control (Burner + Circulator)

This is the simplest and most energy-efficient approach, where the thermostat controls both the burner and circulator. Programmable thermostats enhance efficiency by lowering temperatures during unoccupied periods and reheating before occupancy.

Always-Hot Boiler with Thermostat-Controlled Circulator

In this setup, the boiler stays continuously hot, and only the circulator is turned on/off by the thermostat. This results in higher operating costs due to constant standby heat losses.

Outdoor Reset Control

This advanced method adjusts boiler water temperature based on outdoor air temperature. As outdoor temperatures rise, boiler temperature decreases, improving energy efficiency over conventional fixed-temperature strategies.















Combined Space and Domestic Water Heating

When a single boiler serves both space and domestic water heating, it must remain at full temperature year-round. This leads to high standby heat losses. For better efficiency, consider separating domestic water heating from space heating systems.

Energy Efficiency and Environmental Considerations

The efficiency of hydronic system depends heavily on factors such as proper system sizing, insulation, and the choice of heat sources. Engineers can implement several strategies to enhance system efficiency and align with sustainability goals.











Table 89. Energy Efficiency in Hydronic Systems

	Efficiency Considerations	Rules of Thumb
	Boiler Selection	Use condensing boilers ($\geq 90\%$ AFUE); size to design load (not peak); consider modulation range 5:1 to 10:1. Refer: AHRI 1500, ASHRAE 90.1
	Heat Emitters	Select based on room load, supply temp, and response needs. Refer: ASHRAE Handbook – HVAC Systems
	Pump Selection	Use ECM variable-speed pumps, size near BEP for best performance. Refer: ASHRAE 90.1, HI Std. 9.6.3
	Pipe Sizing & Layout	Minimize friction losses; avoid oversizing. Use ASHRAE Fundamentals for sizing charts.
	Control Valves	Use PICVs for flow balancing. Improves energy use by 20–30%.
	Zoning & Controls	Programmable thermostats, TRVs, smart zoning. Refer: IECC 2021, ASHRAE 55.
	Pipe Materials	Use PEX, copper, and steel as per pressure/temperature class. Follow ASTM F876, ASTM B88.
	Insulation	Insulate all pipes per IECC: R-3 min for ≤ 1.5 " pipes, R-6 for > 1.5 ".
	System Design	Use primary-secondary piping with hydraulic separation (closely spaced tees or low-loss headers).
	Water Treatment	Maintain pH $\sim 7-9$, oxygen scavengers, inhibitors. Refer: ASHRAE Guideline 12, BSRIA BG50.
	Air Management	Use air separators, auto vents. Improves heat transfer.
	Temperature Setbacks	Reduce supply temp during unoccupied hours. Savings $\sim 5-15\%$.
	Flow Control	Use demand-based pumping (ΔT or ΔP control). Improves part-load efficiency.
	Building Automation (BAS)	Integrate controls for temp, flow, and scheduling. Refer: ASHRAE 135 (BACnet), ASHRAE 90.1.

Summary

Hydronic hot water heating systems offer a reliable, efficient, and comfortable method of space heating. Utilizing a boiler as the heat source, these systems circulate hot water through a network of pipes to heat emitters such as radiators, convectors, fan coil units, or underfloor loops. Heat is transferred primarily through radiation and convection, providing even and quiet heating without the use of forced air.

Summarizing, Pros and Cons of Hydronic Systems

	Parameters	Advantages	Disadvantages
	Installation Cost	Lower cost than complex air duct systems.	Higher upfront cost vs. simple electric or small forced-air heaters for single zones.
	Operating Cost	High thermal efficiency: water transports heat effectively; low energy use.	Costly if insulation or leak prevention is poor.
	Energy Efficiency	Water's high heat capacity moves heat efficiently with small pipe volume (~0.03% air volume).	Freeze risks unless antifreeze or backups are used.
	Space Saving	No bulky ducts: flexible tubing is easy to route.	Requires careful pipe layout to avoid damage during renovations.
	Noise Level	Nearly silent; no noisy blowers.	Mechanical pumps may produce minimal noise.
	Zoning & Control	Enables multiple zones with individual thermostats for comfort and savings.	Advanced zoning needs more complex control systems.
	Air Quality / Ventilation	Does not handle ventilation or filtration.	Needs separate ventilation system (HRV/ERV) for fresh air and air quality control.
	Humidity Control	Can be combined with Air Handling Units (AHUs) for humidity control.	Adds complexity and cost if combined.
	Leak & Freeze Risk	Mitigatable with glycol mix, draining, backup power.	Leaks can damage structures; freeze risk without protections.
	Versatility of Heat Source	One boiler can serve multiple uses: heating, DHW, pool, snow melting.	Boiler/pump maintenance can be complex compared to standalone furnaces.
	Integration with Air Systems (AHU)	Can integrate with AHU coils to add ventilation and humidity control.	Integration reduces simplicity, quietness, and space-saving benefits.

Proper sizing, water flow control, and emitter selection are critical to achieving desired comfort levels and system performance. With robust design, regular maintenance, and quality components, hydronic heating systems offer longevity, adaptability, and a superior indoor climate for residential and commercial spaces.

CHAPTER 4: RADIANT FLOOR HEATING SYSTEM

Radiant floor heating differs from forced air heating or heat emitters in that it heats floor and other objects such as furniture and furnishings. It works by circulating hot water through a series of pipework loops embedded in the floor. A thermoplastic or synthetic rubber tube is typically used on 6"-12" centers, cast in the center or placed beneath the slab. Warm water is pumped through these tubes from manifolds located in a convenient location, typically at one end of the space.



Figure 23. Radiant Floor Heating System

Radiant heating provides evenly distributing warmth across every room while lowering energy bills by operating at reduced temperatures. It delivers exceptional comfort and efficiency to both new construction as well as a retrofit project.

Key Features of Floor Heating System

Radiant floor systems use the floor, not the piping, as the heat emitter, distributing warmth evenly across the space. By heating from the floor up, it creates ideal temperature gradients about 75°F at floor level, declining to 68°F at eye level, then to 61°F at the ceiling. This makes them especially effective in spaces with high ceilings by minimizing heat stratification and reducing the need for higher air temperatures.

Design Factors

Hydronic floor heating requires a network of pipes, manifolds, and controls. A well-designed system will include an appropriate boiler and pump sized to handle the load.

Floor heating system outputs vary depending upon the specific relationship between the tubing size, tube spacing, water flowrate and temperature directly represent the heat output (in Btu/sq. ft/hr.) of the radiant heating system.

Table 90. Radiant Floor System – Design Factors

	Design Factor	Rules of Thumb
	Floor Surface Temperature	Max comfortable: 85°F; ideal: 80–82°F (ASHRAE 55; ANSI/ASHRAE 62.1)
	Heat Output Capacity	15–25 Btu/h/ft ² depending on insulation & floor finish (ASHRAE Handbook HVAC Apps)
	Floor Covering	Tile/concrete best; carpet/wood reduce output by 20–40% (ASTM C627; ACI 302.1)
	Pipe Spacing	6–12 inches typical; closer spacing = higher output (PEX guidelines; ASTM F876)
	Flow Rate	2–4 ft/s for proper heat transfer and noise control (Hydronics Institute; ASHRAE)
	Water Supply Temperature	Typically, 100–120°F; lower temps for well-insulated buildings (ASHRAE Handbook)
	Insulation Below Slab	Minimum R-10 under slab (IECC)
	Room Heat Loss	Match output to peak heat loss (Manual J; ASHRAE Handbook)
	Tube Diameter	½ inch PEX common; larger for longer loops (ASTM F877; manufacturer specs)
	Loop Length	Max 250–300 ft per loop (PEX guidelines; ASHRAE Hydronics)
	Control Strategy	Use zoning and thermostats (ASHRAE 90.1; BACnet)
	Slab Thickness	Thicker slabs = more thermal mass, slower response (ACI 302.1; ASHRAE Handbook)
	Manifold Location	Close to zones to minimize piping heat loss (Hydronics Institute)
	System Response Time	Typically, 1–3 hours depending on slab mass and covering (ASHRAE Handbook)
	Indoor Setpoint Temperature	Design for 70–72°F (21–22°C) (ASHRAE 55)

Note: To increase the floor output for selected tubing size and length, the flow may need to be increased, the tubing spacing may be closer together, or an increase in water temperature. For example, by increasing the flow through 1/2" PEX tubing by only 0.1 GPM, floor output will increase at 5 Btu/sq. ft/hr.

Design Steps

Systems are designed using the same principles outlined for hot water space heating. Most of the equipment is the same: heater or boiler, circulating pump, expansion tank, valves, and controls.

To design a radiant floor system, one must determine the:

- a. BTU/h/ft² heat loss for each room
- b. Floor surface temperature
- c. Project installation method
- d. Piping type and size
- e. Finished floor material R-value
- f. Piping on-center distance
- g. Supply water temperature
- h. Loop length, including leader distance
- i. Fluid flow in GPM
- j. Pressure loss or head

The following comments are specific to floor heating:

Heat load for a Room

A simple rule-of-thumb for BTU requirements is to figure that you need about:

- a. 50 Btu/h/ft² in a cold climate
- b. 35 Btu/h/ft² in a moderate climate
- c. 20 Btu/h/ft² in a mixed warm climate.

As an example, if you have a 200 sq. ft room in a moderate climate, you need a heater that can provide 35 Btu/h/ft² or produce approximately $200 \times 35 = 7000$ Btu/h.



Caution: This is a rule of thumb information. Always calculate the real load based on outdoor air and indoor air conditions, number of walls and windows, material of construction, ventilation, and infiltration etc. Add 10 to 15% margin for unknowns.

Once you determine the heat load in Btu/h, work out the key performance indicator, which is the heat load per square feet area by dividing the heat load (Btu/h) by the floor area (in square feet). The floor heating design is based solely on the floor area.

Floor Surface Temperature

The heat transfer to the space is influenced by the floor surface temperature, which is dependent solely on a simple relationship between the room setpoint temperature and the heating capacity to keep up to the heat loss in Btu/h/ft². There are certain guidelines to limit the floor surface temperatures. These are:

Table 91. Ideal Floor Surface Temperature

	Flooring Type / Condition	Rules of Thumb for Surface Temperature
	General Comfort Range	Ideal floor temperature: 77–85°F
	All Flooring Types (General Max)	Max surface temperature: 85°F to avoid discomfort
	Hardwood Floors	Max surface temperature: 80°F or per manufacturer's limit

The required floor surface temperature can be determined by using the table below.

Room Setpoint	Heat Load (Btu/h/ft ²)									
	10.0	15.0	20.0	25.0	30.0	35.0	40.0	45.0	50.0	55.0
75°F	80.0	82.5	85.0	87.5	90.0	92.5	95.0	97.5	100.0	102.5
72°F	77.0	79.5	82.0	84.5	87.0	89.5	92.0	94.5	97.0	99.5
70°F	75.0	77.5	80.0	82.5	85.0	87.5	90.0	92.5	95.0	97.5
68°F	73.0	75.5	78.0	80.5	83.0	85.5	88.0	90.5	93.0	95.5
65°F	70.0	72.5	75.0	77.5	80.0	82.5	85.0	87.5	90.0	92.5
60°F	65.0	67.5	70.0	72.5	75.0	77.5	80.0	82.5	85.0	87.5

- a. The yellow cells on the chart indicate that the floor temperature exceeds the maximum permissible limit of 85°F.
- b. When hardwood flooring is present, the grey cells indicate that the floor temperature exceeds the limits of 80°F.

Let's look at an example of how to use a table. Consider a room with a setpoint temperature of 65°F and a heat load of 35 Btu/h/ft². The required floor surface temperature is found at the point where the two values intersect. This value is 82.5°F.

The next step is to determine whether the temperature of the floor surface is within acceptable limits.

- a. **Check #1:** If the floor surface temperature is no higher than 85°F, it is OK.
- b. **Check #2:** If the design includes wood flooring, it exceeds the maximum temperature limit of 80°F. It fails the test.

What are your options in this situation?

You have two options here: reduce heat loss in the room or add supplemental heat.

This reference table assists HVAC designers in validating whether the Room Design conditions are achievable for a given heat load. If not, supplemental heat may be required.

Equation 14. Estimate Floor Surface Temperature

A simplified equation to estimate the floor surface temperature is:





$$\text{Floor Surface Temp.} = \frac{\text{Heat output (Btu/h/ft}^2\text{)}}{\text{Coefficient (Btu/h/ft}^2\text{/}^\circ\text{F)}} + \text{Room Temp. Setpoint (}^\circ\text{F)}$$

The coefficient of radiant floor thermal transfer is approximately 2.0 Btu/h/ft²/°F. Therefore, the equation becomes:

$$\text{Floor Surface Temp.} = \frac{\text{Heat output (Btu/h/ft}^2\text{)}}{2} + \text{Room Temp. Setpoint (}^\circ\text{F)}$$

For example, if the heat output from the floor is 35 Btu/h/ft² and the room temperature setpoint is 65°F, you will need to maintain a floor temperature of 82.5°F.

$$\text{Floor surface temperature} = \frac{35}{2} + 65 = 82.5^\circ\text{F}$$

	Description	Rules of Thumb
	Floor Surface Temp Estimate	Surface Temp = Room Temp + (0.5 × Btu/h/ft ² heat load)
	Room Temperature Estimate	Room Temp = Surface Temp - (0.5 × Btu/h/ft ² heat load) Example: 30 Btu/h/ft ² load + 80°F floor surface → Room Temp ≈ 65°F
	Floor Heat Transfer Coefficient	2 Btu/h/ft ² /°F
	Radiant Wall Transfer Coefficient	1.8 Btu/h/ft ² /°F
	Radiant Ceiling Transfer Coefficient	1.6 Btu/h/ft ² /°F

Pipe Materials

Usually, this is plastic.

- a. Higher strength 125 psi polybutylene, polyethylene can be used, as well as soft copper tubing.
- b. Oxygen-berried PEX-A tubing is recommended to minimize the potential for corrosion.

Pipe Sizing

The most common pipe sizes in radiant floor heating are 3/8" and 1/2". Both are almost equal in terms of heat output per square foot. Remember, the floor is the heat emitter, not the piping. The piping merely carries water to the heat emitter.

The key difference is the pressure loss; smaller pipes have higher loss, requiring shorter loops. Pipe size mainly affects loop length, not heat output. Performance depends more on spacing, water temperature, floor material, and flow rate. The table below provides standard guidelines.

Table 92. Pipe Sizing for Radiant Floor Heating





	Factors	Rules of Thumb
	Room Size & Heat Demand	Small rooms: 3/8" or 5/8" pipe; Larger rooms/high demand: 3/4" pipe
	Pipe Length	Max loop length: 3/8" ≤ 200 ft; 1/2" ≤ 300 ft; 5/8" ≤ 400 ft
	Pipe Spacing	3/8" pipe: 4–6"; 5/8" pipe: 6–8"; 3/4"+ pipe: >10"
	Floor Type	Tile/concrete (high conductivity) → wider spacing; Wood/carpet (low conductivity) → closer spacing
	Flow Velocity	Maintain ≤1 m/s (3 ft/s) to avoid noise and wear

Table 93. Standard Pipe Sizes







	Pipe Size	Rules of Thumb
	12 mm (3/8")	Ideal for retrofits with thin screeds; requires closer spacing and higher flow; common in residential.
	16 mm (5/8")	Most common size; suits most residential and commercial applications.
	20 mm (3/4")	Used in large areas or high heat loss zones; allows higher water flow; suited for large commercial & snowmelt systems.

Table 94. Pipe Spacing

	Design Consideration	Rules of Thumb
	Closer Pipe Spacing	Increases heat output and speeds system response; allows lower supply temperature; improves surface temp uniformity.
	Wider Pipe Spacing	Requires higher water temperature; may cause hot/cold striping; suitable for non-critical spaces (warehouses, storage).
	Max Spacing for Poured Underlayment	Limit spacing to 9 inches on-center to avoid striping effects.

Equation 15. Calculate Coil/Roll Length for Underfloor/Radiant Heating

$$\text{Pipe Length (ft)} = [(\text{Total Area (ft}^2\text{)} / \text{Pipe Spacing (ft)}) + \text{Transit Pipe Length (ft)}] \times 1.1$$







Where:





- Pipe Length: The total pipe length required for the room or zone.
- Total Area: Room area covered by radiant heating (ft²)
- Pipe Spacing: The distance between each pipe loop (common values: 4” – 12”).
- Transit Pipe Length: The length of pipe required to connect the manifold to the heated area.
- 1.10: This multiplier adds 10% to account for the extra pipe needed for bends and connections.

Supply Water Temperature

Supply water temperature is based on a complex relationship between the conditions above and below the radiant mass and several other characteristics of the installation.

Table 95. Supply Temperatures – Radiant Floor Heating

	Factors	Rules of Thumb
	Ideal Water Temperature Range	100°F–130°F typical; 100–110°F for well-insulated buildings or tile/concrete floors
	Room Heat Loss / Load	Higher Btu/h/ft ² → higher water temp needed to maintain comfort
	Ambient Outdoor Temperature	Colder climate → higher supply temperature during peak cold periods
	Room Setpoint Temperature	Higher setpoint (e.g., 75°F vs 70°F) → increased supply temperature required
	Supply-Return ΔT (Temp Drop)	Typical ΔT: 10–20°F; smaller ΔT means higher flow; larger ΔT may require higher supply temperature
	Water Flow Rate	Low flow → poorer heat transfer, requires higher water temperature

	Pipe Spacing	Closer spacing → lower water temperature needed, better heat distribution
	Floor Covering	Tile/concrete allows lower temp; carpet/wood insulate more, requiring higher water temperature
	Insulation Below Slab	Better insulation reduces downward heat loss, allowing lower water temperature
	System Response Time Needs	Faster warm-up may require slightly higher water temperature

Notes:

- The hot water supply temperatures are much lower in the range of 85 -140°F for floor heating systems as compared to 140 to 170°F for other space heating systems.
- The system is designed to work with a 10 to 15°F temperature difference between the supply and the return.

Water Flowrate

Hot water flow rate is based on a relationship between the heat load, active loop length and the supply and return differential temperature.

Equation 16. Estimating Flowrate (GPM)

$$\text{Flowrate (GPM)} = \frac{\text{Heat Output (Btu/h)}}{500 \times \Delta T (^{\circ}\text{F})}$$

Where:

- Heat Output is the amount of heat required, calculated in BTU/h.
- ΔT = the temperature difference between the flow and return water, usually taken as 10 to 15°F
- 500 is a constant based on the specific heat of water and conversion to GPM (gallons per minute).

Important: Radiant floor heating systems are usually designed for ΔT of 10 - 15°F as compared to 20°F, 25°F or 30°F for other hydronic emitters. This means that: the water flowrate for radiant floor heating systems will be higher than for space heaters using radiators or convectors for similar heat load or the boiler capacity.







Pressure Loss

In a hot water radiant floor heating system, pressure loss refers to the resistance encountered by circulating water as it flows through pipes, fittings, manifolds, and floor loops. This loss is caused by friction within the piping and any elevation changes or flow restrictions. High pressure losses can reduce system efficiency, requiring more powerful circulator pumps to maintain adequate flow rates and even heat distribution. Proper pipe sizing, loop lengths, and flow balancing are essential to keeping pressure losses within acceptable limits.

The pressure drop calculations can be performed using Hazen-Williams or Darcy equation. To calculate the feet of head loss for the loop, use the following information:

- a. Flow per loop
- b. Total loop length
- c. Size of piping
- d. Type of piping
- e. Supply water temperature and fluid concentration.

Table 96. Pressure Loss Criteria

	Parameter	Rules of Thumb
	Maximum Loop Length	3/8": ≤ 200 ft; 1/2": ≤ 300 ft; 5/8": ≤ 400 ft to minimize pressure drop and maintain flow balance
	Typical Head Loss	~1.0 to 4.0 ft of head per 100 ft of pipe length
	Common Circulator Head	Residential systems typically use circulators with ~20 ft head capacity
	Total System Flow (GPM)	Add flow of all loops served by one circulator (cumulative)
	Total System Head (ft)	Use highest pressure drop among loops on manifold (not cumulative)
	Circulator Selection	Select pump based on manufacturer's curve matching required GPM and head

1.1.24 Controls

Radiant floor heating systems rely on a combination of control components to regulate heat output, maintain comfort, and optimize energy efficiency. These controls manage temperature settings, water flow, pump operation, and system response based on indoor and outdoor conditions. Below is an overview of the key control mechanisms used in hydronic radiant floor heating systems:

- a. **Thermostats (Room or Zone Control):** Thermostats monitor room temperature and signal the system to activate or deactivate accordingly. Each room or zone typically features its own thermostat to enable individual temperature control.
- b. **Actuators (Thermal or Motorized):** Actuators respond to thermostat signals by opening or closing the loop valves on the manifold. This allows precise control of water flow to each zone, ensuring consistent room temperature.
- c. **Manifold with Flow Meters and Balancing Valves:** Flow meters display the actual water flow rate in each loop (commonly in L/min or GPM), while balancing valves allow fine-tuning of flow in each loop to maintain uniform heat distribution.
- d. **Circulator Pump Control:** Circulator pumps may operate with simple on/off control based on a heat call from any thermostat, or as variable-speed pumps that adjust flow based on system demand (pressure or temperature). Advanced systems may use PWM or 0–10V control for greater energy efficiency.
- e. **Mixing Valve / Temperature Control Valve:** These valves blend hot water from the boiler with cooler return water to maintain a consistent supply temperature, typically not exceeding 120°F, to protect floor finishes. Common types include thermostatic mixing valves and electronic mixing controllers.
- f. **Outdoor Reset Controls:** These controls adjust the supply water temperature based on the outdoor temperature, improving energy efficiency and comfort by reducing overheating during mild weather.
- g. **Boiler Control Integration:** Integrates the radiant heating system's heat demand with the boiler operation to ensure coordinated and efficient heating.
- h. **Smart Control:** Advanced systems may include a central controller that manages domestic hot water priority, zone sequencing, and boiler staging for optimal performance.
- i. **Floor Sensor (Optional):** Optional floor sensors measure surface temperature to enhance comfort, prevent cold floor surfaces, and avoid overheating of flooring materials such as wood.

Manifold Placement and Setup

Manifold distributes heated water from the boiler to the circuit loops under the floors. Properly positioning and setting up the manifold is critical to ensuring the efficiency and performance of your system, whether you're installing it in a small home or a large commercial space.

Suitable Placement for the Manifold

- a. **Centralized Location:** Ideally placed centrally within the heated space to minimize the length of pipe runs and ensure even heat distribution.
- b. **Accessible Area:** Should be installed in a location that's easily accessible for maintenance, such as a utility room, cupboard, or basement.
- c. **Ventilated Space:** Place the manifold in a well-ventilated area to prevent overheating and ensure the system operates efficiently.
- d. **Avoid Damp Areas:** Ensure the manifold is installed in a dry area, away from potential water damage.
- e. **Height Considerations:** For easier installation and maintenance, mount the manifold at a comfortable working height (typically between 1m to 1.5m from the ground).

Limitations to Consider

- a. **Distance from Heat Source:** Avoid placing the manifold too far from the boiler or heat pump to minimize heat loss in the pipes.
- b. **Pipe Length Restrictions:** Limit the pipe runs from the manifold to prevent pressure drops and ensure consistent water flow; generally, pipe runs should not exceed 100m for a 16mm pipe.
- c. **Space Constraints:** The manifold requires sufficient space for installation, including enough clearance around the pipes, valves, and controls for easy access.
- d. **Noise Sensitivity:** In residential settings, avoid placing the manifold near bedrooms or living spaces, as it can produce operational noise.
- e. **Multi-Story Buildings:** In multi-story installations, consider separate manifolds for each floor to simplify the pipework and improve system control.

Floor Heating Installation - Pipe Placement and Concrete Reinforcement

Radiant floor heating systems depend on the long-term reliability of embedded piping and the structural design of the floor slab. For optimum performance, the system must be integrated into concrete with proper reinforcement and thermal insulation. These elements ensure durability, safety, and energy efficiency.

Pipe Placement Options



Radiant heating pipes (typically PEX or similar materials) can be installed using two common approaches:

- a. In a Sand Layer Beneath the Slab: Pipes are placed in a compacted sand or gravel bed, with the concrete slab poured over it. This method simplifies installation and reduces the risk of pipe damage from slab cracking. However, it is slightly less efficient due to thermal resistance from the sand layer.
- b. Directly Embedded in Concrete: This is the preferred method for maximum heat transfer. Pipes are laid directly within the slab during the pour. Though more efficient, this method requires careful slab reinforcement to minimize stress on the piping caused by concrete shrinkage and natural cracking.

Reinforcement Requirements

Concrete undergoes shrinkage as it cures, which can cause cracking, potentially damaging embedded heating pipes. Proper reinforcement ensures long-term structural stability and protects the system.

Table 97. Floor Reinforcement

	Reinforcement Needs	Rules of Thumb
	Purpose	Minimizes cracking and distributes stress; essential when control joints can't be placed over pipes
	Control Joints	Avoid placing control joints directly over embedded pipes; rely on reinforcement instead
	Recommended Steel Ratio	Minimum 0.16% of slab cross-sectional area for steel reinforcement to control shrinkage cracking and protect piping







Material Compatibility and Durability

Always select radiant heating tubing specifically manufactured for concrete embedding. The tubing should be pressure-rated, oxygen-barrier equipped, and withstanding long-term exposure to curing chemicals, temperature fluctuations, and potential mechanical stress from slab movement.

Insulation Requirements

Proper insulation is essential for thermal efficiency, comfort, and long-term system performance. Heat loss to the ground or unconditioned spaces must be minimized to ensure that the energy used for heating is delivered where it's needed, into the occupied space.





Table 98. Radiant Floor Insulation

	Floor Insulation	Rules of Thumb
	Location	Always insulate beneath radiant floors to prevent downward heat loss
	Recommended Materials	Use extruded polystyrene (XPS) boards (blue, pink, green, yellow) - rigid, moisture-resistant, durable
	Slab-on-grade Floors	Minimum 2 inches of XPS insulation recommended
	Upper-level Wood Floors	Minimum R-13 insulation required below radiant tubing
	Unsuitable Materials	Avoid white bead board (EPS) and polyurethane , prone to moisture damage and compression
	Perimeter Insulation	Insulate vertical slab edges with XPS material
	Moisture Protection	Install vapor barrier below insulation and slab to block ground moisture

1.1.25 Floor Coverings









For floors occupied by people with bare feet (in swimming halls, gymnasiums, dressing rooms, bathrooms, and bedrooms), flooring material is important. Ranges for some typical floor materials are as follows:

Table 99. Ideal Floor Surface Temperature

	Floor Coverings	Ideal Floor Surface Temperature
	Textiles (rugs)	70°F to 82°F
	Pine floor	72°F to 82°F
	Oak floor	76°F to 82°F
	Hard linoleum	75°F to 82°F
	Concrete	79°F to 83°F

Typical hot water supply temperature will need to be higher for floors with coverings that insulate the floor e.g., carpets, wood/manufactured wood coverings etc.

Table 100. Radiant Floor Installation Guidelines

	Installation	Rules of Thumb
	Installation Types	Slab-on-grade, thin-slab (1.5"–2"), dry systems (above/below deck)
	Fluid Routing	Start circuits along exterior walls to offset higher heat loss
	Pipe Routing	Maximize straight runs; minimize bends; use sweeping turns >12" radius
	Circuit Length	Max 300 ft per loop (½" PEX), ≤15°F ΔT
	Zoning	One zone per room for control and efficiency (higher upfront cost)
	Control Joints	Avoid crossing tubes; if necessary, sleeve with 2x pipe diameter
	Grid Placement	6"–12" spacing typical; tighter near exterior walls
	Tube Crossover	Avoid tubing crossovers in layout
	Tube Protection	Prevent tube puncture during concrete pouring or flooring installation

System Costs

Rough estimates are as follows:

- a. Material Supply: \$130 to 150 per square feet.
- b. Installation Cost: \$ 50 to \$ 60 per square feet.

Note that very small areas will be more expensive than above.

1.2 Radiant Floor Heating – Sample Problem

Design a floor heating system for a room 32' x 50'. The floor area inside the foundation is about 30' x 48' = 1440 sq-ft. Calculate the system size based on 70 Btu/sq-ft heat input.

Solution

Room floor area = 1440 sq-ft

Calculate system size based on 70 Btu/h/sq-ft heat input.

Total Heat input = 70 Btu/h/sq-ft x 1440 sq-ft = 100800 Btu/h (or ~ 30 kW capacity)

Determine flow rate for an inlet- outlet hot water temperature change of 10°F across the system

$$\text{Flowrate (GPM)} = \frac{\text{Heat capacity (Btu/h)}}{500 \times \Delta T (\text{°F})}$$

$$\text{Flowrate} = \frac{96600}{(500 \times 10)} = \sim 20 \text{ GPM}$$

Determine number of loops and water quantity per loop

Each loop is about 100 ft (~2 x 48') long, thus ¾" pipe will be adequate (Note: double loops of 184 ft length could be run to reduce valves and connections).

Room width = 30 ft

Pipe spacing = 1.5 ft

Number of lines = 30/1.5 = 20

Therefore, use 20 lines or 10 loops

Water flow in each loop = $20/10 \text{ GPM} = 2 \text{ GPM}$

Size the header system:

For a flow of 20 GPM, 2" (50 mm) pipe is more than adequate.

Estimate the volume of the system

1000 ft* of $\frac{3}{4}$ " floor pipe x 0.025 gallons per ft = 25 gallons {Note *...100 ft loop x 10 loops; the $\frac{3}{4}$ " pipe has a holding capacity of 0.025 gallons per ft of pipe}

60 ft* of 2" mm header x 0.16 gallons per ft = 9.6 gallons {Note*...2 x 30 ft of supply & return header; the 2" pipe has a holding capacity of 0.16 gallons per ft of pipe}

Boiler unit volume (estimated) = 5 gallons







Total = 39.6 gallon

Minimum expansion capacity required is 5% of 39.6 gallon = 1.98 gallon; obtain an expansion tank with at least 2-gallon net expansion capacity.

Summarizing....

Radiant floor heating systems offer a highly comfortable, energy-efficient solution for space heating by delivering warmth evenly from the ground up. Leveraging the combined effects of conduction, radiation, and convection, these systems provide consistent thermal comfort while reducing energy consumption, especially when using low-temperature water. However, they come with limitations such as slow responsiveness, higher installation costs, and challenges in accessing embedded piping for maintenance. Careful planning and supplementary systems can help address these issues and maximize the benefits.

Table 101. Pros & Cons of Radiant Floor Heating

	Pros	Cons
	Delivers heat via conduction, radiation, and gentle convection, enhances comfort	Slow response; longer heat-up time
	Uniform heating across the floor surface	May need supplementary heating in extreme cold
	High thermal mass retains heat longer, reducing energy cycling	Higher upfront cost vs. conventional systems
	Operates at lower water temperatures, boosting energy efficiency	In-slab piping hard to access for repairs/maintenance
	Accelerates snow and ice melting (outdoor use)	
	Quiet, clean operation; no dust or air movement	
	Reduces air stratification, improving comfort at lower thermostat settings.	

There are also floor heating systems that use electrical wiring installed under flooring materials, typically ceramic or stone tile. These are less energy efficient than hot water systems and are typically used only in small rooms such as bathrooms. They primarily heat the floor in such a way as to keep your feet warm, but not so much the room itself.







CHAPTER 5: HEAT PUMP SYSTEMS

A heat pump is a highly efficient climate control system that provides both heating and cooling. It operates on the same basic principle as an air conditioner, moving heat rather than generating it, but with the added ability to reverse the process. While an air conditioner only cools indoor spaces by transferring heat from inside to outside, a heat pump can reverse this process, extracting heat from the outside air (even in cold weather) to warm indoor spaces. This dual-mode approach essentially allows heat to be “pumped” in either direction, hence the name “heat pump.”



Figure 24. Air Source Heat Pump

Table 102. Heat Pumps for Heating & Cooling

	Features	Rules of Thumb
	Heat Generation	Heat pumps transfer heat using vapor compression; do not generate heat directly.
	Reversible Operation	Provide both heating and cooling via reversing valve switching refrigerant flow.
	Primary Mode Selection	Select heating- or cooling-dominant mode based on climate and building usage.
	Outdoor Unit Functionality	Outdoor unit absorbs heat in heating mode; rejects heat in cooling mode.
	Energy Efficiency	Best for moderate climates; higher COP than resistance heaters.
	Typical COP (Heating)	Air-source heat pumps: COP of 3–4 in mild climates.
	Supplemental Heat	Below ~17°F outdoors, supplemental heat (electric strip/gas furnace) may be necessary.

1.3 Heat Pump Components

A heat pump consists of several key components that work together to transfer heat between indoor and outdoor environments. Here are the principal components and their functions:

Evaporator Coil

Function: A heat exchanger that absorbs heat from the surrounding air. For heating, it is the outdoor unit and for cooling, it is the indoor unit.

How it works: A refrigerant inside the coil evaporates at low pressure, absorbing heat in the process.

Compressor

Function: It circulates refrigerant through the system and raises its pressure and temperature, allowing it to condense at a higher temperature in the condenser coil. Common compressor types include reciprocating, rotary, and scroll.

How it works: Compresses the low-pressure refrigerant vapor from the evaporator, turning it into a high-pressure, high-temperature vapor before sending it to the condenser.

Condenser Coil

Function: A heat exchanger that releases heat to the environment. For heating, it is the indoor unit. For cooling, it is the outdoor unit.

How it works: The high-pressure refrigerant condenses into a liquid, releasing the heat it absorbed earlier.

Expansion Valve (or Metering Device)

Function: Reduces the pressure of the refrigerant before it enters the evaporator. There are two types of expansion devices: fixed flow area type (capillary and orifice) and thermostatic expansion (TEX) valve. TEX valves are used where there is a varying load on the evaporator.

How it works: Allows the high-pressure liquid refrigerant to expand and cool, enabling it to absorb heat in the evaporator.

Reversing Valve (specific to heat pumps)

Function: Changes the direction of the refrigerant flow to switch between heating and cooling modes. Its position is controlled by a heating/cooling thermostat.

How it works: Activates based on the thermostat setting, allowing the same system to heat or cool a space.

Indoor Fan (Air Handler)

Function: Circulates conditioned air throughout the indoor space.

How it works: Draws air over the indoor coil (evaporator or condenser, depending on mode) and distributes it through ductwork.

Outdoor Fan

Function: Draws air over the outdoor coil to assist in heat exchange.

How it works: Helps expel or absorb heat from the environment, depending on the mode of operation.

These components work in a closed loop using a refrigerant to transfer heat efficiently, making heat pumps an effective solution for both heating and cooling. The preferred refrigerants for heat pump applications are R407C, R410A and R134a which are hydrofluorocarbons (HFC). All these have zero ozone depletion potential (ODP) and a very little Global warming potential (GWP).

Type of Heat Pumps

Heat pumps are classified based on the low-temperature heat source:

- a. Air-source heat pump: Heat is transferred from the low-temperature air outside to the high-temperature interior.
- b. Ground-source heat pump: The earth is used as a heat sink in the summer and a heat source in the winter; the pump relies on the relative warmth of the earth for its heating and cooling production.
- c. Water-source heat pump: Heat is transferred from low-temperature water outside (from a pond or a lake) to a high-temperature interior.

Air Source Heat Pumps (ASHP)

An air source heat pump (ASHP) operates like an air conditioner in summer, removing heat from indoors and releasing it outside to cool the space. In winter, it reverses the process, extracting heat from the outdoor air and transferring it indoors. This is made possible by a reversing valve, while the other components remain like those of a standard air conditioner. The ability to both heat and cool make ASHPs an energy-efficient and cost-effective solution for year-round comfort.

Schematic diagram of reverse-cycle, air-to-air, split system heat pump operation is shown below.

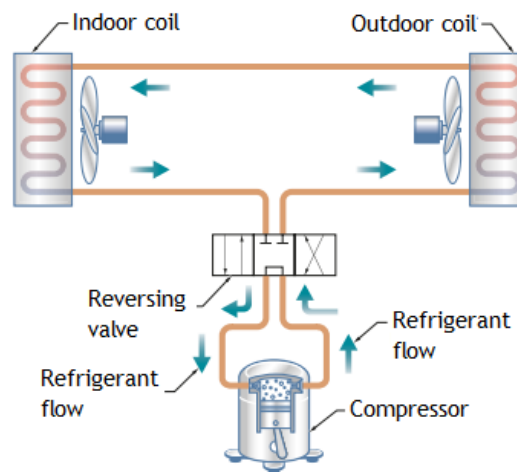

Air Source Heat Pump Schematic Diagram

Figure 25. Air Source Heat Pump Schematic Diagram

ASHP Operation

In cooling mode, liquid refrigerant in the indoor evaporator coil absorbs heat from the building's interior and refrigerant gas in the outdoor condenser coil releasing the heat to the outside. The compressor supplies the necessary energy to drive this heat transfer process.

In heating mode, a reversing valve changes the direction of the refrigerant flow. The outdoor coil acts as the evaporator, absorbing heat from the outside air, while the indoor coil becomes the condenser, releasing heat into the circulating air or liquid to warm the indoor spaces.

The operation of an ASHP during heating and cooling cycles is illustrated in the figures below.

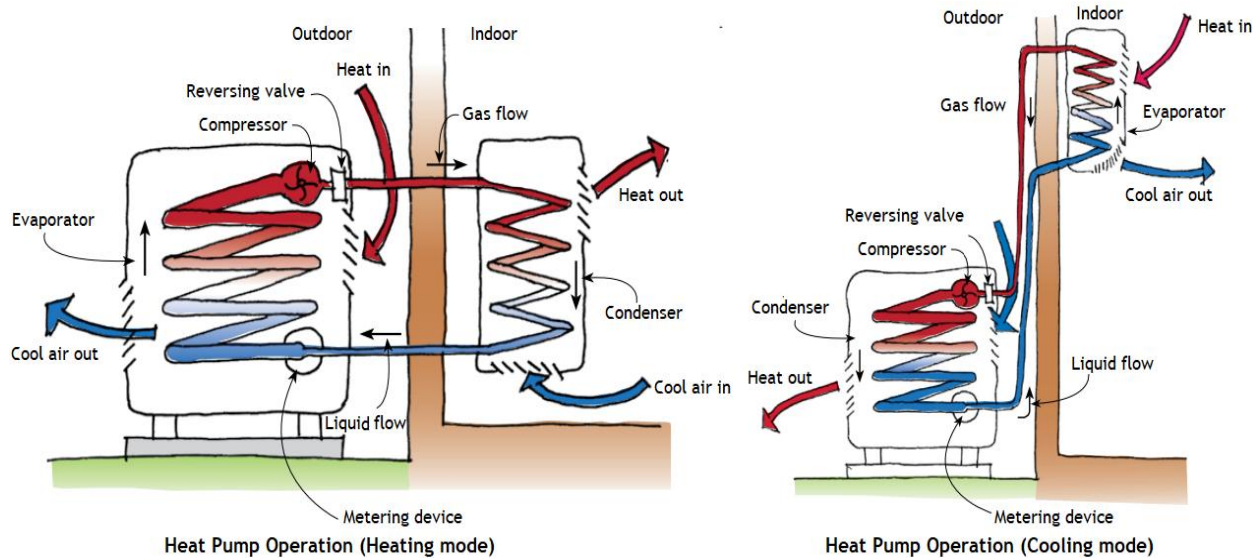

Figure 26. Heat Pump Operation

Benefits and Limitations of Heat Pump

The outside air always contains usable heat, even in cold weather. In milder climates, heat pumps offer highly efficient heating and cooling by moving existing heat rather than generating it from another energy source, achieving 150–300% more heat output than the electricity consumed. However, their efficiency declines when outdoor temperatures drop below 40°F, often requiring auxiliary electric or gas heating. In areas with consistently freezing temperatures, geo-thermal systems are a more reliable and efficient alternative.

ASHP Design Configurations

Air-source heat pumps are classified by:

- a. Type of equipment used
- b. Layout of equipment
- c. Method of distributing air conditioning

Single-split system

A single split heat pump connects one outdoor unit to one indoor unit.

- It's ideal for heating or cooling a single room or zone.
- Each system is independent, so multiple single splits can be installed in a building if needed.

- They are simple to install and generally lower in cost.
- Common in residential homes, small offices, or individual spaces.

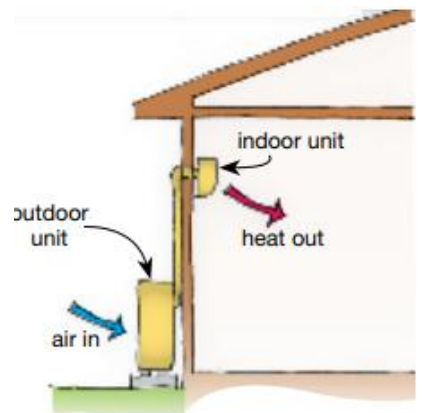

Split System Heat Pump

Multi-split system

A multi split heat pump connects one outdoor unit to multiple indoor units (usually 2–5, but sometimes more).

- Each indoor unit can operate independently, allowing different rooms to be heated or cooled separately.
- Good for larger homes or small commercial buildings where space-saving and zone control are important.
- Requires more complex piping and installation but reduces the number of outdoor units compared to multiple single splits.

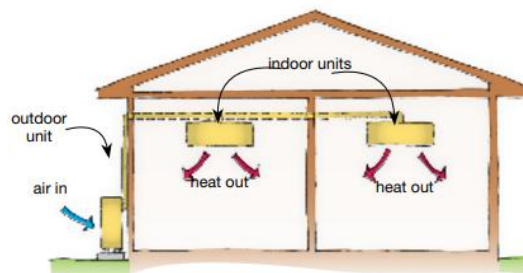

Multi-Split System Heat Pump

Ducted system

A ducted split heat pump connects an outdoor unit to a central indoor unit, which distributes conditioned air through a system of ducts hidden in ceilings or walls.

- Provides whole-building heating and cooling with a discreet appearance (only vents or grilles are visible).
- Offers even temperature distribution across rooms.
- Ideal for larger homes, commercial spaces, or projects prioritizing aesthetic and centralized control.
- Installation is comparatively complex and expensive, especially when equipped with zones controlled individually (using variable air volume, VAV boxes) or by a centrally located controller.

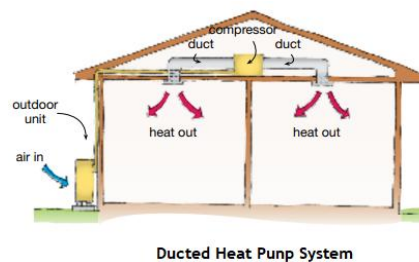

1.3.1 Indoor Units

Indoor units are defined according to positioning. They may be:

- a. High wall-mounted units: These units blow air down or out of the unit to circulate the warm air within the room.
- b. Ceiling cassette-mounted units: These units blow hot or cool air along the ceiling to mix with room air before dropping to the level of occupants.
- c. Floor console: These units are generally used for heating, as air circulation occurs from warm air rising and cold air falling.

All three types of units can be used for heating or cooling.



High wall-mounted unit



Ceiling cassette-mounted unit



Floor console unit

Clearances

Appropriately for room layout and airflow patterns in accordance with the manufacturer's recommendations for minimum clearances – otherwise allow as per figure below.

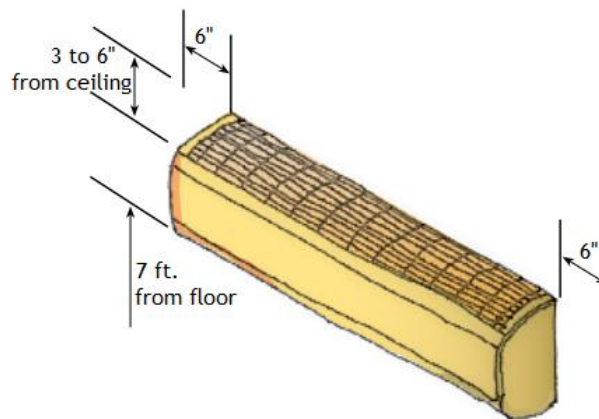

Figure 27. Indoor Split Unit Clearances

1.3.2 Outdoor Units

Locate outdoor units where noise from the unit cannot transmit to and disturb the home occupant or adjacent properties. Install in accordance with the manufacturer's recommendations for refrigerant tube lengths and distances to obstructions. Provide the following minimum distances from obstructions: 1.5 feet between air inlet and outlet faces, 2 feet above the unit, 6 inches to other faces.

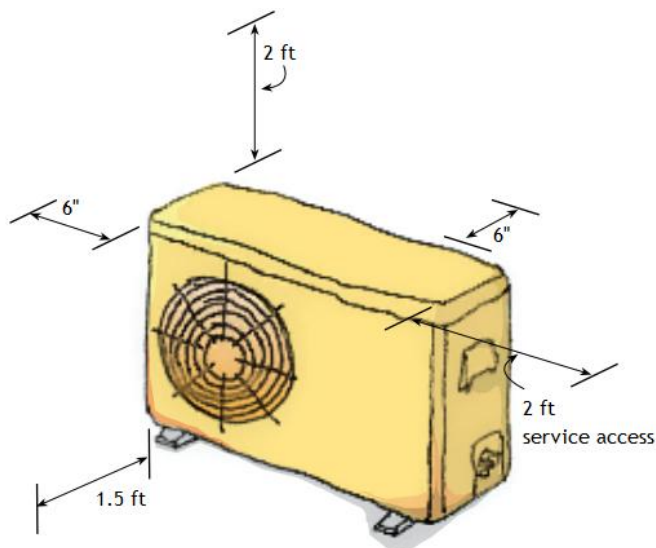

Figure 28. Outdoor Split Unit Clearances

Ground-Source (Geothermal) Heat Pumps (GSHP)

Instead of using air, ground source heat pump (GSHP) extracts heat from the earth through a network of buried pipes. During winter, fluid circulating through underground pipes called a “ground loop” absorbs heat from the earth and transfers it indoors. The indoor unit compresses the heat to a higher temperature and distributes it throughout the building. In summer, the process reverses: the system removes heat from the building and transfers it back into the cooler ground. Essentially, a GSHP uses the earth as a heat source in winter and a heat sink in summer, relying on the earth’s stable temperature to efficiently provide heating and cooling.

- Highly efficient because the ground temperature – three to six feet below the earth’s surface, temperatures remain relatively constant year-round. A GSHP system capitalizes on these stable temperatures to provide “free” energy.
- Used in residential, commercial, and industrial applications.
- Higher upfront cost but very low operating cost over time.

There are two main ways to install the ground loops:

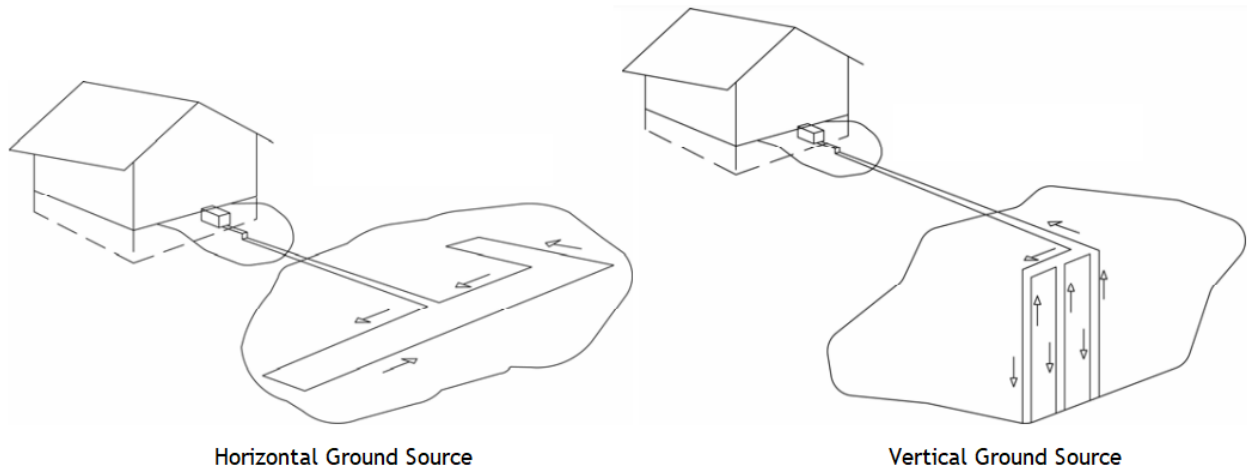

Figure 29. Horizontal GSHP and Vertical GSHP

Horizontal Loops





Pipes are laid out horizontally in long, shallow trenches, usually 3 to 6 feet deep and up to 400 feet long, depending on the number of pipes in a trench. Requires a large area of open land.

Vertical Loops

U-shaped loops of pipe are inserted in the holes. The holes are then grouted from bottom to top to ensure consistent ground contact with the earth. Pipes are installed vertically in deep boreholes typically 100–400 feet deep about 4" dia. and 20 ft. apart. Requires less surface land but drilling is more expensive.

Table 103. Horizontal GSHP vs. Vertical GSHP System

	Feature	Horizontal GSHP	Vertical GSHP
👍	Installation Area	Needs large land area for trenches	Suitable for limited land availability
👍	Installation Depth/Size	Trenches 3–6 ft deep, up to 400 ft long	Boreholes 100–400 ft deep, ~4" diameter, ~20 ft apart
👍	System Capacity Benchmark	~400–500 ft trench length per ton	~180–300 ft borehole depth per ton
👍	Installation Cost	~\$600–\$800 per ton	~\$900–\$1300 per ton
👍	Building Suitability	Residential, low-load buildings	Commercial, high-load buildings

	Feature	Horizontal GSHP	Vertical GSHP
	Soil/Drilling Conditions	Easier in soft soils	Difficult in rocky soil
	Performance Stability	Seasonal soil temp affects heat exchange	More stable heat exchange due to depth
	Loop Configuration	Straight, slinky, spiral loops	Vertical U-tube loops in boreholes
	Pipe/Borehole Requirements	Longer pipe runs	Deeper fewer boreholes; fully grouted with thermal grout
	Installation Speed	Faster for small projects	Longer installation time

Water Source Heat Pump (WSHP)

Water source Heat Pump (WSHP) system uses water bodies like lakes, rivers, or closed water loops as the heat exchange medium. It is different from ground loops in a way that instead of buried loops, a natural water body (like a lake, river, or pond) or a man-made water loop system is used.

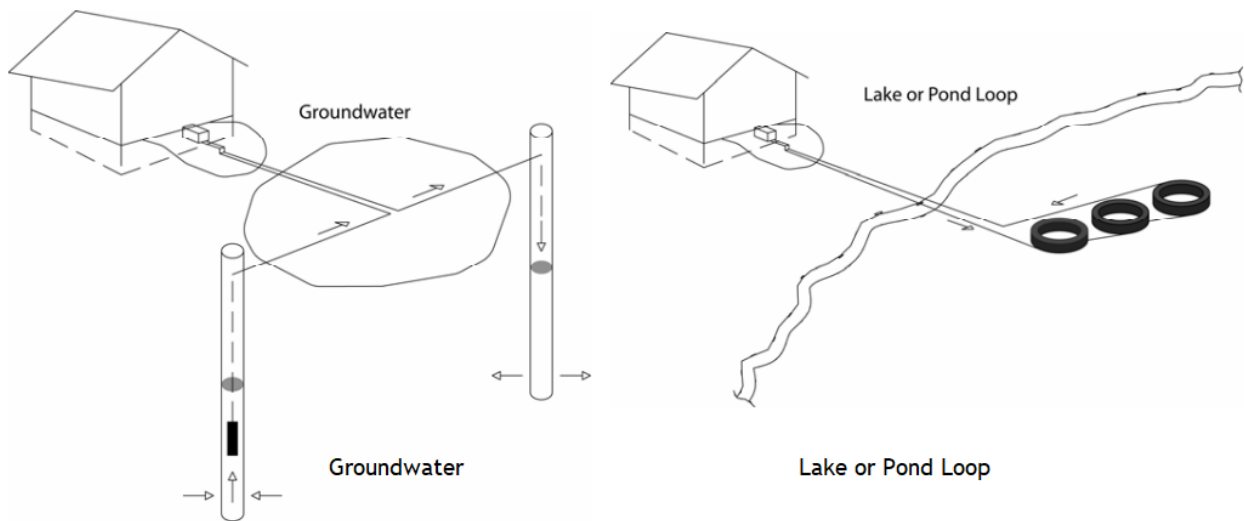

Figure 30. Water Source Heat Pump via Ground Water, Lake or Pond

WSHP systems can be designed as either an open loop or closed loop system.

1.3.3 Open Loop Systems









An open loop system draws water from a natural source like a well, lake, river and pumps it through the heat pump to extract heat, and then discharges back into a stream, river, lake, pond, or a ditch, subject to environmental approvals. Alternatively, water can be returned to the aquifer through a

return well. Compliance with local ordinances, codes, and licensing requirements may be necessary, and local authorities should be consulted for any applicable restrictions.

1.3.4 Closed Loop Systems

A closed loop system circulates environmentally safe antifreeze and water solution through a continuous loop of buried polyethylene pipe, connected to the indoor heat pump. Unlike open loop systems, closed loops recirculate the fluid within sealed, pressurized piping without consuming groundwater.

Table 104. Open Loop vs. Closed Loop WSHP System

	Feature	Open-Loop WSHP	Closed-Loop WSHP
	Water Source	Draws from well, lake, or river	Circulates in sealed underground/underwater loop
	Water Flow	1.5–3 GPM per ton	~3 GPM per ton
	Water Quality	Critical to prevent fouling and scaling	Lower concern: loop fluid maintenance needed
	Environmental Impact	Requires disposal and permits	No discharge; minimal permitting
	Installation Cost	Lower upfront, higher operating risks	Higher upfront, lower maintenance
	Site Suitability	Needs reliable water source	Fits most sites with sufficient land or water
	Pumping Requirements	Pumps sized for extraction and reinjection	Pumps sized for loop circulation
	Seasonal Performance	Water temperature varies seasonally	More stable year-round performance

Geothermal Piping Design Criteria

Closed loop systems should be installed using only high-density polyethylene pipe (HDPE) with thermal fused joints for ground loops. The ASTM number is 3408. PVC pipes should never be used. HDPE pipe is inert to chemicals normally found in soil and have good heat conducting properties. More specific standards for ground loops are available from the International Ground Source Heat Pump Association (IGSPHA).

1.3.5 HDPE Pressure vs. Temperature Rating

HDPE piping uses Standard Dimension Ratio (SDR) for pipe sizing rather than the traditional Schedule sizes. An advantage of SDR ratings is the pressure rating is consistent, regardless of pipe diameter. For instance, SDR 17 is generally rated at 100 PSI for all diameters. SDR 11 is rated at 160 PSI and SDR 9 is rated at 200 PSI at 73°F.

Table 105. HDPE Pipe Pressure Rating at Different Temperatures









	Temperature (°F)	Pressure Rating (PSI)	
		SDR 11	SDR 9
	73	160	200
	80	151	189
	90	138	173
	100	126	157
	110	114	142
	120	102	128
	130	91	114
	140	80	100

Table 106. Pipe Sizes and Water Flow Rates (US GPM)

Pipe Size, Nominal Dia. (in.)	US GPM				
	SDR 11 HDPE	SDR 17 HDPE	Sched 40 Steel	Sched 80 Plastic	Copper Type L
¾	4.5	-	4	3	3.5
1	8	-	7	6	7
1 ¼	15	-	15	13	13
1 ½	22 -	23	21	20	
2	40	-	45	40	44
3	110	140	130	125	130
4	220	300	260	250	260
6	600	750	800	750	800
8	1200	1500	1600	1500	-
10	2200	2600	3000	-	-
12	3500	4200	4600	-	-

*Based on ASHRAE recommended head loss of 4 ft water per 100 ft pipe

Geothermal System Design

Geothermal projects (WSHP and GSHP) are inherently designed for high energy efficiency. To support this goal, the following guidelines are provided to guide the designer:



Flow Rate Design

Benchmark: 3.0 US GPM per ton of system capacity (typical for both WSHP and GSHP).

Variable Flow Systems: Size pumps and controls for modulation down to 33% of design flow.

ASHRAE 90.1 Compliance: Systems >10 HP must use variable flow.

Most geothermal systems are designed at 3.0 US GPM per ton. Lowering flow rates will reduce pump and piping size but also decreases heat pump performance. At 3.0 GPM, expect a 10°F temperature range in cooling and about 6°F in heating when all heat pumps run simultaneously, during startup or cold weather.

	System Flow, US GPM/ton	Temperature Range, Cooling (°F)	Temperature Range, Heating (°F)
	3.0	10	6
	2.5	13	7 to 8
	2.0	15	9

Note: In cooling mode, heat pumps reject both the heat collected from the space and an additional 25% from the compressor, resulting in a wider loop temperature range. In heating mode, the heat absorbed from the loop combines with compressor heat to meet space demand, leading to a smaller temperature range.

Pipe Sizing

Pressure Drop Target: Aim for 4 feet of water pressure drop per 100 feet of piping. Helps balance pumping energy efficiency and pipe cost.

Velocity Limits: Keep fluid velocities < 6 ft/s to avoid excessive noise and erosion. < 3 ft/s is often preferred for glycol solutions to limit pressure drop.

Pipe Materials

Common Materials:

- HDPE (high-density polyethylene) for underground GSHP loops.
- Copper or steel for mechanical rooms and accessible areas in WSHP.

Rating: Pipes must be rated for fluid temperatures (as low as 30°F) and pressure (typically 150 psi minimum).

Loop Configurations

Horizontal Loops (GSHP): Straight, slinky, or spiral layouts; trenches 3–6 ft deep.

Vertical Loops (GSHP): U-bend pipes in 100–400 ft deep boreholes.

Closed-Loop WSHP Systems: Reverse return piping for better hydraulic balance in large systems.

Open-Loop WSHP Systems: Source and discharge pipes from wells, lakes, rivers; piping must withstand biofouling and sediment.

Piping Layout Rules

Reverse Return Preferred: Naturally self-balancing. Balancing valves minimize if flow imbalance is $\leq 15\%$. Alternatively use pressure independent control valves (PICV).

Direct Return Acceptable: If the longest branch accounts for $< 30\%$ of total system head loss.

Isolation and Valves:

- Two-way isolation valves at each heat pump for variable flow.
- Ball valves or butterfly valves for service and isolation.

Grouting and Protection (for GSHP Loops)

Vertical Loops Borehole Grouting:

- Required to avoid aquifer contamination.
- No gravel backfills; use thermal grout with good conductivity.

Horizontal Loops Trench Protection:

- Remove sharp objects.
- Use sand bedding with ≥ 300 mm (12 inches) of cover around pipes.

Thermal Expansion

Flexible Loops: HDPE pipe naturally accommodates some expansion/contraction.

Anchors/Guides: Necessary for long indoor piping runs of steel/copper.

Insulation

Indoor Piping: Insulate all chilled or low-temperature lines to prevent condensation.

Buried Piping: Insulation generally not required unless close to foundations.

System Pressure

Static Pressure Design: Closed-loop systems designed to maintain positive pressure at all points (usually 30–50 psi).

Expansion Tanks: Required to manage fluid volume changes with temperature swings.

Glycol Mixture for GSHP

Freeze Protection: Use propylene glycol or ethylene glycol.

Mixture typically 20–30% glycol by volume depending on the lowest expected ground loop temperature.

Common problems

Because the key components of any ground-source system are buried in the ground, and in some cases under the building, the installation quality must be carefully monitored. Rectification work can be expensive and, in some cases, impossible. The following precautions are recommended.

- a. Minimize joints in pipework design to reduce the risk of poor on-site workmanship.
- b. Individually connect each borehole to accessible valves; avoid daisy-chaining to ensure a single failure affects only one borehole.
- c. Fully grout all boreholes; avoid gravel, which can create pathways for contaminants into aquifers.
- d. Prepare trenches carefully, free of stones and sharp objects, with sand bedding and at least 12 inches of cover on all sides.
- e. Train all site operatives in electrofusion jointing; require test samples from each before starting work.
- f. Conduct independent testing of all interconnecting pipework before backfilling, and third-party inspection of boreholes.

Minimum Efficiency Requirements

The Federal Energy Management Program (FEMP) created tables that mirror American Society of Heating, Refrigerating and Air-Conditioning Engineers (ASHRAE) 90.1-2013 tables, which include minimum efficiency requirements for FEMP-designated and ENERGY STAR-qualified heating and cooling product categories.





Heat Pumps – Energy Efficiency

Electrically Operated Unitary Heat Pumps: Minimum Efficiency Requirements				
Equipment Type	Size Category	Heating Section Type	Subcategory or Rating Condition	Minimum Efficiency
Air-cooled (cooling mode)	<65,000 Btu/h	All	Split system	15.0 SEER; 12.5 EER; 8.5 HSPF (single phase ^a)
			Single package	15.0 SEER; 12.0 EER; 8.2 HSPF (single phase ^a)
	≥65,000 Btu/h and <135,000 Btu/h	Electric resistance (or none)	Split system and single package	11.8 EER; 12.8 IEER; 3.4 COP at 47°F
	≥135,000 Btu/h and <240,000 Btu/h	Electric resistance (or none)	Split system and single package	10.9 EER; 12.0 IEER; 3.3 COP at 47°F
	≥240,000 Btu/h ^b	Electric resistance (or none)	Split system and single package	9.5 EER; 10.6 IEER
Geothermal, closed loop water-to-air				17.1 EER; 3.6 COP (single phase)
Geothermal, open loop water-to-air				21.1 EER; 4.1 COP (single phase)
Geothermal, closed loop water-to-water				16.1 EER; 3.1 COP (single phase)
Geothermal, open loop water-to-water				20.1 EER; 3.5 COP (single phase)
Geothermal, DGX				16.0 EER; 3.6 COP (single phase)
^a Three phase heat pumps in the <65,000 Btu/h category are not covered by ENERGY STAR ^b Heat pumps with size equal to or greater than 240,000 Btu/h are not covered by federal purchasing requirements. Minimum efficiency presented is consistent with ASRHAE 90.1-2013 Table 6.8.1-2.				

Course Summary

In this course, we learned about four different types of central heating systems namely: Forced air furnaces, hydronic heat radiators, and floor heating, as well as heat pumps including air-to-air and geothermal sources.



The table below compares these systems for a 1500 square feet residential space.

	Central Heating System (1500 ft ²)	Description	Approx. purchase/install price (Note 1) *	Annual Heating Costs (Note 2) *
	Furnace (Forced Air)	Heat from combustion warms air, distributed via ducts.	\$4,000 – \$6,000	\$110–270 (4–5 star) / \$160–360 (1–2 star)
	Boiler (Hydronic)	Combustion heats water, circulated to radiators, convectors, or FCUs via insulated pipes.	\$5,000+	\$100–350 (natural gas)
	Radiant Floor Heating	Hot water flows through tubes embedded in floors (or walls/ceilings) for radiant heat.	~\$3 per ft ²	\$100–1,352
	Heat Pump (Reverse-cycle AC)	Uses electricity and refrigerant to transfer heat or cooling via a reversible refrigeration cycle.	\$8,000 – \$12,000	\$120–220

Note 1: Initial cost is for a 1500 square feet residential space.

Note 2: Operating cost is for a winter quarter of 90 days, 8 hours per day, at an average indoor temperature of 65°F.

Table 107. Conclusive Comparison of different Heating Systems

	System Type	Installation Cost	Operating Cost	Maintenance Cost	Safety	Life-Cycle Cost
	Combustion-Based (Boiler/Furnace)	Moderate	Moderate	High	Moderate Concern	Moderate
	Heat Pump (Electrical)	Moderate	Moderate	Moderate	Excellent	Moderate
	Geothermal / Ground-Source Heat Pump	High	Low	Low	Excellent	Low









References

- ASHRAE Handbook - HVAC Systems and Equipment
- DOE Furnace and Boiler Standards (2023)
- CIBSE Guide B – Heating, Ventilation, Air Conditioning and Refrigeration
- Bell & Gossett Engineering Design Manual
- Plumbing Engineering Design Handbook (Vol. 2), American Society of Plumbing Engineers (ASPE)
- Hydronic System Design for Energy Efficiency – U.S. Department of Energy
- Manufacturer Technical Guides (e.g., Taco, Grundfos, Lochinvar)
- Carrier System Design Manual

ANNEXURE 1: KEY RULES OF THUMB

Heat Loss Approximation based on Climate Zones in USA

Heating equipment sizing often starts with rough estimates that are useful during initial design phases. However, HVAC designers should use these estimates for validation, not as final definitive values. Accurate equipment selection and sizing must be based on detailed heat loss calculations that consider specific building characteristics, construction, insulation levels, climate zones, and occupancy patterns. This ensures both performance efficiency and occupant comfort while avoiding the risks of under- or over-sizing.

	Climate Zone	Climate Type	Heat Loss (Btu/h·ft ²)	Key Consideration
	Zone 1 (Miami, FL)	Hot, Humid	5–10	Minimal heating, focus on cooling
	Zone 2 (Houston, TX)	Warm, Humid	10–15	Mild winters, low heating demand
	Zone 3 (Atlanta, GA)	Hot-Dry/Mixed-Humid	15–25	Moderate heating, temp swings
	Zone 4 (Washington, D.C.)	Moderate	20–35	Moderate heating, varying humidity
	Zone 5 (Chicago, IL)	Cool	30–50	Significant heating, insulation crucial
	Zone 6 (Minneapolis, MN)	Cold	40–60	High heating load, very cold winters
	Zone 7 (Denver, CO)	Very Cold	50–70	Very high heating load
	Zone 8 (Anchorage, AK)	Subarctic/Arctic	70–100+	Extreme heating load, severe winters















As an example, if you have a 2,000-square-foot house in a Washington, D.C. area (climate zone 4), you need a boiler that can produce approximately 70,000 Btu/h at 35 Btu/h.ft².

Note: The heat loss calculations are carried out for the worst-case scenario: the coldest night of the year. Because the coldest temperatures usually occur at night, a heat-loss calculation excludes solar gain through windows.







Common Heating Systems and Equipment

- Hydronic Heating Systems: Uses boilers to generate hot water or steam.
- Forced Air System: Uses furnaces to heat air.

Comparison: Hydronic Heating (Boiler) vs. Forced Air Heating (Furnace)

	Factors	Hydronic Heating (Boiler + Radiators/Radiant)	Forced Air Heating (Furnace + Ducts)
	Operating Principle	Heats water, circulates to emitters; radiant and convective heat transfer.	Burns fuel to heat air, distributes via ductwork.
	Fuel Source	Natural Gas, LPG/Oil, Electric	Natural Gas, LPG/Oil, Electric
	Supply Temp.	140–180°F (standard); 120–160°F (high-efficiency condensing boilers)	100–140°F (typical); ~100°F for high-efficiency furnaces
	Return Temp.	100–120°F	65–75°F
	Temperature Rise (ΔT)	20–40°F	20–60°F (typically ~40°F)
	AFUE Efficiency	80–85% standard; up to 98% condensing (DOE min. 80%, cold zones 90%+)	78–85% standard; up to 98% condensing (DOE min. 80%, 90%+ cold)
	Heat Distribution	Even radiant heat, stable temperatures	Convective, can be drafty and uneven
	Distribution Losses	Minimal (insulated pipes)	20–30% losses due to duct leakage
	Zoning	Simple, room-level control	Complex; requires dampers
	Comfort & Air Quality	Clean, no air movement	Airflow spreads dust/allergens
	Noise Level	Quiet	Fan and airflow noise (30–60 dB)
	Installation Cost	Higher: \$8–15/ft ²	Lower: \$5–10/ft ²
	Operating Cost	Lower (efficient heat transfer)	Higher (duct losses)
	Lifespan	20–30 years	15–20 years

Space Heating Furnace: Fuel Selection Criteria

	Parameters	Rules of Thumb
	Fuel Type	Natural Gas, LPG, Fuel Oil #2, Electricity. Choose based on availability and economics.
	Heating Capacity	Measured in British Thermal Units per hour (Btu/h).
	Natural Gas Furnace	<p>Most common and most economical fuel for furnaces where available as piped gas.</p> <ul style="list-style-type: none"> • Heat Content: ~1,030 Btu/ft³ • Benchmark: 100 ft³ ≈ 100,000 Btu of heat • AFUE Range: 80%-98% • Clean burning with relatively low emissions.
	LPG (Propane) Furnace	<p>Commonly used in rural areas without natural gas lines. Delivered and stored in pressurized tanks.</p> <ul style="list-style-type: none"> • Heat Content: Higher energy content about 2.5 times more than natural gas (~2,500 Btu/ft³ or ~91,500 Btu/gal) • Benchmark: 1 gallon ≈ 91,500 Btu • AFUE Range: 80–98% • Burns cleanly but is typically more expensive per Btu than natural gas.
	Fuel Oil#2 Furnace	<p>Preferred in rural or industrial areas without gas infrastructure.</p> <ul style="list-style-type: none"> • Heat Content: ~139,000 Btu/gal • AFUE Range: 80–90% typically • Benchmark: 1 gallon ≈ 139,000 Btu of heat • Requires on-site storage tanks and delivery via tanker. • Higher emissions compared to natural gas.
	Electric Resistance Furnace	<p>Ideal for small spaces, mild climates, or areas without fossil fuel access.</p> <ul style="list-style-type: none"> • Heat Content: 1 kW = 3,412 Btu • Benchmark: 10 kW ≈ 34,120 Btu/hr • AFUE Equivalent: 100% (resistance heat) • 1 kW = 3,412 Btu's heat • No combustion or venting required. • Highest operating cost in many regions.
	Life Expectancy	<ul style="list-style-type: none"> • Gas furnaces: 15–20 years. • Oil furnaces: 15–25 years. • Electric furnaces: 20–30 years.





Fuel Selection Economics

Fuel Type	Cost per Unit	Heat Content per Unit	Effective Heat (Btu) at 85% Efficiency	Cost per Btu (\$)	Cost per 100,000 Btu (\$)
LPG (Propane)	\$2.50/gal	91,500 Btu/gal	77,775 Btu/gal (91,500 × 0.85)	\$0.032 (\$2.50 ÷ 77,775)	\$3.20 (\$0.032 × 100,000)
Natural Gas	\$1.50/therm	100,000 Btu/therm	85,000 Btu/therm (100,000 × 0.85)	\$0.0176 (\$1.50 ÷ 85,000)	\$1.76 (\$1.50 ÷ 0.85)
Fuel Oil #2	\$3.50/gal	139,000 Btu/gal	118,150 Btu/gal (139,000 × 0.85)	\$0.030 (\$3.50 ÷ 118,150)	\$3.00 (\$0.030 × 100,000)



Results: Natural gas is the cheapest at \$1.76, followed by fuel oil at \$3.00, and LPG at \$3.20 per 100,000 Btu delivered.

Notes: Costs are 2025 estimates; efficiency adjusts usable heat output. Natural gas benefits from direct therm pricing (1 therm = 100,000 Btu), simplifying its calculation.





Furnace Construction

	Furnace Type	Rules of Thumb
	Upflow	Air enters bottom, heated air exits top. Most common. Best for basements or closets with overhead ductwork.
	Downflow	Air enters top, and heated air exits bottom. Ideal for attics, garages, or homes with ducting beneath floors (crawl spaces).
	Horizontal	Installed sideways; air discharges left or right. For crawl spaces, attics, low clearance areas. Requires special mounting and drainage.
	Availability	Residential: 40k–120k+ Btu/h (20k increments). Multiple small units improve efficiency. Commercial: Up to 1,000,000 Btu/h for large/custom systems.





Cost Comparison

	Furnace Costs	Rules of Thumb
	Capital Costs (Residential Furnaces)	Order low to high: Electric < Gas 80% AFUE < Gas 90%+ AFUE < Oil. Electric: \$2,000–\$6,000 (size & features affect cost) Gas 80% AFUE: \$3,000–\$7,000 (standard efficiency) Gas 90%+ AFUE: \$4,000–\$10,000+ (20–40% higher cost for high efficiency) Oil Furnace: \$6,000–\$10,000+ (includes tank/fuel setup)
	Operating Costs	Varies by fuel type & cost, natural gas cheapest, electric resistance highest cost. Higher AFUE (90%+) significantly lowers fuel use vs. 80%. Calculation: $(\text{Load} \div (\text{AFUE} \times \text{Fuel Btu})) \times \text{Fuel Cost} + \text{Electric Cost}$. Operating cost depends heavily on climate and insulation level.





Furnace Heat Transfer Method

	Heat Transfer Method	Rules of Thumb
	Furnace Classification	Heating furnaces are classified as direct-fired or indirect-fired. Heat transfer mainly by convection; some radiation.
	Direct Fired Furnace	No heat exchanger; direct combustion. Used for ventilated spaces (warehouses, garages). Range: 50–80 Btu/h/ft ² . Airflow: 3.5–4.5 CFM per 1,000 Btu/h.
	Indirect Fired Furnaces	Combustion gases separated from air for better quality. Range: 30–60 Btu/h/ft ² . Airflow: 1–3 CFM per 1,000 Btu/h. Heat exchanger size: 0.8–1.2 ft ² per 10,000 Btu.
	Radiant Type Furnaces	Heat via radiation, focused on people or zones. Good for high ceilings or large open areas. Range: 20–40 Btu/h/ft ² . Radiant tubes: 1 per 500–1,000 ft ² .





Furnace Efficiency (AFUE)

	Furnace Types	Rules of Thumb
	Standard Efficiency	70–85%, non-condensing, single heat exchanger. DOE min. 80% (2023). Good for mild/moderate climates.
	Mid-Efficiency	85–89%, non-condensing, enhanced single heat exchanger. Suitable for moderate climates.
	High-Efficiency	90–98%, condensing with dual secondary heat exchanger. Recommended for cold/severe cold climates.
	Sizing Guideline	Follow climate-appropriate AFUE for efficiency and energy savings.





Furnace Control Mechanism

	Furnace Control	Rules of Thumb
	Single Stage	On/off at 100%. Best for mild climates. Lower cost, less precise comfort.
	Two-Stage	Two levels: Low (~60%) & High (100%). Better comfort, efficiency, quieter, good humidity control.
	Modulating	Continuous output 40–100%. Precise temp control ($\pm 0.5^\circ\text{F}$). Best for large homes/cold climates. Highest efficiency.
	Zoning	Use dampers and multistage/modulating furnaces with variable-speed blowers for multi-zone comfort.

Furnace Drafts & Vents





	Drafts	Description	Vent Design
	Natural Draft	Relies on buoyancy; uses indoor air; ~80% AFUE or less.	1 in ² / 4,000 Btu/h
	Induced Draft	Fan-assisted; better control; ~80–83% AFUE.	1 in ² / 4,500 Btu/h
	Forced Draft	Blower-driven; positive pressure; used in commercial systems.	1 in ² / 5,000 Btu/h (max 15 ft vent)
	Sealed Combustion	Uses outdoor air; direct vent; 90–98% AFUE; safer and more efficient.	PVC/CPVC/stainless, 1 in ² / 5,000 Btu/h

Furnace Categories and Vents



	Furnace Category	Rules of Thumb
	Category I	Non-condensing, negative pressure, flue temp >140°F. AFUE ≤83%. Uses Type B metal vent or lined chimney.
	Category II	Condensing, low flue temp <140°F, negative pressure. Requires corrosion-resistant venting.
	Category III	Non-condensing, positive pressure, flue temp >140°F. Needs gas-tight, pressure-rated vent materials.
	Category IV	High-efficiency condensing, positive pressure, flue temp <140°F. AFUE ≥90%. Needs corrosion-resistant vent + drain.

Note: Vent must be large enough to carry away all flue products but not so large that it cools gases too quickly, affecting draft (for Cat I) or causing condensation in non-approved areas. Common Sizes (Cat IV PVC): 2", 3", sometimes 4" diameter for residential. Sizing depends on furnace input, vent length, number of elbows, and vent material. Refer to NFPA 54 (National Fuel Gas Code) or local codes.





Furnace Operation: Supply Air and Temperature Range

	Parameters	Rules of Thumb
	Supply Air Temp	104–122°F typical; max 100–140°F (ASHRAE).
	Temperature Rise (ΔT)	40–60°F typical. Low ΔT : cool drafts; high ΔT : overheating risk.
	Recirculation Air Temp	Maintain 65–70°F for efficiency.
	Airflow (CFM)	130-310 CFM per 10,000 Btu/h (based on ΔT). Equation: $CFM = 10,000 \div (1.08 \times \Delta T)$. ≈ 310 CFM per 10,000 Btu/h for 30°F temperature rise (ΔT). ≈ 185 CFM per 10,000 Btu/h for 50°F temperature rise (ΔT). ≈ 130 CFM per 10,000 Btu/h for 70°F temperature rise (ΔT).





Combustion Air Openings by Space Classification









	Parameter	Rules of Thumb
	Confined Space	Volume < 50 ft ³ per 1,000 Btu/h input → Extra combustion air openings required.
	Unconfined Space	Volume ≥ 50 ft ³ per 1,000 Btu/h input → No extra combustion air needed.
	Space Type Determination	<ol style="list-style-type: none"> Add total Btu/h of all appliances. Divide by 20 → get minimum room volume (ft³). <p>Analysis: If room volume < result → confined; if ≥ result → unconfined.</p>

Furnace Installation by Space Classification









	Scenario	Rules of Thumb	
		Opening Location	Minimum Free Area
	Confined Space – Inside Air	Two openings: one high, one low within 12" of ceiling & floor.	1 in ² per 1,000 Btu/h, minimum 100 in ² per opening (e.g., 100,000 Btu/h → 2 × 100 in ²).
	Confined Space – Outdoor Air, Vertical Duct	Two openings: one high, one low within 12" of ceiling & floor.	1 in ² per 4,000 Btu/h per opening (e.g., 100,000 Btu/h → 25 in ²)
	Confined Space – Outdoor Air, Horizontal Duct	Two openings: one high, one low within 12" of ceiling & floor.	1 in ² per 2,000 Btu/h per opening (e.g., 100,000 Btu/h → 50 in ²).
	Unconfined Space	No additional openings required	50 ft ³ per 1,000 Btu/h

High-Efficiency Furnaces for Space Heating





	Parameters	Rules of Thumb
	Efficiency (AFUE)	90–98%; 95%+ for cold climates. Minimum 90% per DOE 2023 for condensing.
	Vent Material	Use PVC/CPVC or stainless steel (Category IV, corrosion-resistant).
	Vent Sizing	1 in ² per 5,000 Btu/h (e.g., 4" vent for 80k–120k Btu/h). Must be leak-tight.
	Condensate Mgmt.	0.5–1 gal/day; sloped drain (¼" per foot), trap required. Follow manufacturer's guide.
	Air Supply	Use sealed/direct vent with outdoor air intake.

	Parameters	Rules of Thumb
	Install Location	Prefer conditioned areas; avoid freezing spaces.
	Sizing	30–60 Btu/h·ft ² for load; add 10–15% buffer. Avoid oversizing.
	Draft Type	Forced draft, positive pressure: +0.05 to +0.2 in. WG.
	Blower Type	Single-speed: basic; multi-speed: better comfort; Variable-speed (ECM): best performance.
	Zoning Capability	Best with variable-speed and 2-stage/modulating furnaces; uses dampers + thermostats.
	Thermostat	Single stage: basic (R, W, G). Two-stage: needs 2-stage stat. Modulating: often proprietary.
	Energy Savings	Save 20–30% vs. 80% AFUE. Higher upfront, lower lifecycle cost.
	Codes & Standards	Follow NFPA 54 for venting, local codes for installation.













Furnaces: Codes & Standards (NFPA 54 / IFGC Mandatory Requirements)



	Requirements	Mandate
	Certification	UL/CSA listed for fuel type. (NFPA 54 §9.1.4, IFGC §301.3)
	Installation	Follow the manufacturer’s instructions/NFPA 54.
	Combustion Air	Indoor: ≥50 ft ³ /1,000 Btu/h; Outdoor: 1 in ² /4,000 (vertical), 1 in ² /2,000 (horizontal). (NFPA 54 Ch. 9)
	Location	Not allowed in bedrooms/baths unless sealed. (NFPA 54 §10.1.2, IFGC §303.3)
	Venting	Match to furnace category; size per code. (NFPA 54 Ch.12, IFGC Ch.5)
	Safety Controls	Include auto ignition, shutoffs, high-limit switches. (NFPA 70)
	Gas Piping	Size per code, shutoff within 6 ft, drip leg required. (NFPA 54 Ch.6)
	Testing	Leak + operation test; ≥3 psi. (NFPA 54 §8.1, IFGC §406)
	Access	3" min in front of controls. (NFPA 54 §9.3.1, IFGC §306.1)

Heating Furnaces: ANSI Z83.4 & Z83.18 - Emissions Requirements















	Emission	Benchmark Value/Rules of Thumb
	ANSI Z83.4 (100% OA)	CO ≤ 5 ppm, NO ₂ ≤ 0.5 ppm, CO ₂ ≤ 4,000 ppm. Ref: ANSI Z83.4
	ANSI Z83.18 (Recirc. Air)	CO ≤ 25 ppm, NO ₂ ≤ 3 ppm, CO ₂ ≤ 5,000 ppm. Ref: ANSI Z83.18
	Combustion Efficiency	≥ 78% (non-condensing), ≥ 90% (condensing).
	Spillage	No flue gas spillage after 5 minutes of operation. Ref: NFPA 54 §9.3.4.3
	Flame Failure Response	Automatic shutdown within 0.8–3 sec after flame loss. Ref: ANSI Z21.20 / Z83 Series

Furnace Installation Dos and Don'ts











	DO's	Details	Rules of Thumb
	✓	Proper Vent Sizing	1 in ² /4,000 Btu/h (natural draft), 15–20 ft height, ¼ in./ft pitch (NFPA 54).
	✓	Use Correct Materials	Type B (Cat. I), PVC/CPVC (Cat. IV).
	✓	Ensure Air Supply	50 ft ³ /1,000 Btu/h (unconfined); use outside air for confined spaces.
	✓	Install Safeties	Shutoffs, dampers, firestops; wire draft inducers properly.
	✓	Minimize Bends	Limit to 2 elbows; each adds 10% loss. Laterals <75% of vent height.
	✓	Proper Installation	Allow 30" clearance, install in alcoves, closets, attics, etc.
	✓	Location	Place centrally near the ducting and vent/chimney exits.
	✓	Cooling Configuration	Furnace upstream or parallel to A/C coil to prevent condensate issues.
	✓	Codes/Standards	Comply with NFPA 54, NFPA 70, local codes; consult authority.
	DONT's	Details	Rules of Thumb
	✗	Oversize/Undersize Vents	Avoid < needed (spillage) or >50% excess (draft failure); follow fan specs.
	✗	Use Unlined Chimneys	Line masonry chimneys to avoid corrosion.
	✗	Vent Near Inlets	Keep ≥7' above grade, ≥3' above air inlets, ≥4' from windows/doors.

	DO's	Details	Rules of Thumb
	✗	Rely on Infiltration	Use proper ducts/grilles, not building leaks for combustion air.
	✗	Install on Combustibles	Avoid carpet, tile, or flammables (wood floor okay).
	✗	Install Uninsulated Outdoors	Don't use single-wall vents outside; insulate or use double-wall.



Hot Water Heating using Boilers

	Parameters	Rules of Thumb
	Boiler Type	Conventional: 80–85% AFUE, Condensing: >90% AFUE. (DOE, ASHRAE 90.1)
	Sizing	Match load +10–15%. Avoid oversizing. (Manual J, ACCA S)
	Fuel Types	Natural Gas, LPG, Oil, Electric. Choose based on cost, availability, emissions.
	Efficiency (AFUE)	Gas/Oil: 80–95%, Electric: ~100%.
	Input Rating	Btu/h input used for gas pipe/vent sizing. (NFPA 54, IFGC Ch.4)
	Output Ratings	DOE (Heated area), IBR Gross/Net (Unheated). Net = 0.85 × Gross.
	Venting Categories	I: Nat. Draft, II: Condensing/Neg, III: Power, IV: Condensing/Pos. (ANSI Z21.13)
	Draft Type	Natural, Induced, Sealed (best for condensing).
	Life Expectancy	Cast Iron: 25–35 yrs; Condensing: 15–20; Electric: 20–30.
	Boiler HP (BHP)	1 BHP = 33,475 Btu/h ≈ 1,000 ft ² .
	Heat Load per Area	~38 Btu/h/ft ² or 0.12 kW/m ² . Adjust by climate.
	System Pressure	12–25 psig typical. (ASME BPVC)
	Condensate Mgmt.	Neutralize; slope drain ¼"/ft. (IPC 701.9, Mfr Spec)
	Controls	Outdoor reset, LWCO, PRV, flame safety, zoning.
	Common Pitfalls	Oversizing, no reset, poor piping, missing exp. tank, air traps.

Hot Water Circulating Pumps









	Parameters	Criteria
	Capacity (Pump Flowrate)	$GPM = \text{Btu/h} \div (500 \times \Delta T^{\circ}\text{F})$. Example: 1 GPM per 10,000 Btu/h @ 20°F ΔT.
	Pump Head	Overcome system friction, valves, coils; elevation usually ignored (closed loop).
	Pump Types	Centrifugal: end-suction (small), split-case (large), vertical inline (compact). Positive displacement for dosing only.
	Efficiency	Select near BEP; meet ASHRAE 90.1 efficiency.
	Operating Speed	Prefer 1750 RPM for a quieter, longer life.
	VFD Use	Improves energy & flow control. Must for modulating boilers (ASHRAE 90.1)
	Control Method	Use VFDs instead of throttling valves for efficiency.
	NPSH	Ensure $NPSH_a \geq NPSH_r + 3\text{--}5$ ft to prevent cavitation.
	Space	Use compact inline or vertical pumps for tight spaces.
	Cost	Evaluate life-cycle cost; higher efficiency reduces operating cost. (DOE Pump Guide)

Pump Location





	Pump Location	Pros	Cons
	Downstream Boiler (Pumping Away)	<ul style="list-style-type: none"> ✓ Reduces cavitation risk ✓ Stabilizes system pressure ✓ Improves temperature control. 	<ul style="list-style-type: none"> ✗ Requires higher pump head ✗ Higher temperature may reduce pump lifespan.
	Upstream of Boiler (Pumping Into)	<ul style="list-style-type: none"> ✓ May reduce pump head requirements ✓ Protects pump from high temperatures 	<ul style="list-style-type: none"> ✗ Increases cavitation risk ✗ Less stable system pressure ✗ Poorer temperature control ✗ Higher risk of boiler thermal shock

Note: In some complex systems, upstream pumping may be necessary but carefully evaluate potential risks.



Hydronic Pipe Sizing Criteria

	Features	Rules of Thumb
	Velocity	2–4 ft/s (<2" pipe, residential); 4–8 ft/s (>2" pipe, commercial). Min 0.5–2 ft/s to avoid air/sediment. (ASHRAE, UPC)
	Friction Loss	Target <4 ft/100 ft; ideal 2–3 ft/100 ft for efficiency.
	Pipe Sizing	Use equal friction or limiting velocity methods; friction loss prioritized.
	Pipe Material	Copper (Type L/M), PEX (ASTM F876/877), Steel Sch 40 (ASTM A53). Select per durability, corrosion, flexibility.
	Insulation	1" fiberglass (<2" pipe), 1.5" (>2" pipe). (ASHRAE 90.1-2022, IECC 2021 C404.4)
	Flowrate	0.5–2 GPM per residential loop; ~1 GPM per 10,000 Btu/h @ 20°F ΔT
	Supply/Return Temps	Supply: 140–180°F; Return: 120–160°F; ΔT ~20°F. Lower temps for condensing/radiant systems. (ASHRAE 90.1, UPC)
	Operating Pressure	12–25 psig typical; allow +5 psig over highest point. (IBC, ASME BPVC)
	Pressure Relief Valve	Set ~30 psig residential. (ASME BPVC Section IV)
	System Pressure Rating	Pipe must handle 1.5× design pressure per ASME B31.1/B31.9
	Expansion Allowance	Steel: 0.12%/100°C; PEX 5–15× more. Use expansion tanks, loops, joints sized for ≥10% system volume or 1 gal/50,000 Btu/h
	Valves/Fittings	Full-port ball valves, balancing valves, sweep elbows; minimize fittings.
	Water Distribution	Two-pipe direct with PICV or reverse return for auto balance; primary-secondary for variable flow/multi-zone.
	System Layout	Minimize length/fittings; use long radius bends; air vents at high points.
	Balancing	Use PICVs, balancing valves, reverse return for equal flow.

Hydronic Piping Materials

	Piping Material	Pipe Size	US Standard	Applications	Benchmark Figures
	Welded Mild Steel	½" – 6"	ASTM A53/A106, Sch. 40	Moderate pressure & temperature	285 psi at 100°F, up to 800°F
	Welded Carbon Steel	8" – 18"	ASTM A53/A106, Sch. 40/80	Higher pressure & temperature	285 psi at 100°F, up to 800°F
	ERW Carbon Steel	20" – 24"	ASTM A53, API 5L Grade B, X/XXS	Very large diameter applications	285 psi at 100°F, up to 800°F
	Copper	Up to 2"	ASTM B88	Refrigerant lines, hot/chilled water	400 psi, up to 400°F
	PEX	Up to 1"	ASTM F876, F877	Radiant heat, snow melt, hot water	160 psi, up to 200°F







Recommended Pipe Sizing Criteria: Velocity vs. Friction Loss Method

	Criteria	Velocity Method	Friction Loss Method
	Benchmark Values	≤8 ft/s max; ideally <4 ft/s for ≤2" pipes, <6 ft/s for >2" pipes	Friction loss <4 ft/100 ft for efficiency
	Focus	Control noise & erosion	Minimize pump head & maintain pressure balance
	Recommendations	Prioritize velocity for pipes >16" for lifecycle cost	Prioritize friction loss for pipes ≤16"; cross-check both









Pipe Sizing Tables: Flowrates (GPM) at different Velocity and Pressure drop

Pipe Size (inches)	Velocity Criteria		Pressure Drop Criteria		
	Flow (GPM) @ 4 fps	Flow (GPM) @ 6 fps	Flow (GPM) @ 2 ft/100 ft	Flow (GPM) @ 3 ft/100 ft	Flow (GPM) @ 4 ft/100 ft
1/2"	3	,	1.1	1.3	1.5
3/4"	7	,	2.4	3.0	3.4
1"	12	,	4.4	5.3	6.2
1 1/4"	17	,	7.1	8.7	10.1
1 1/2"	24	,	10.8	13.2	15.3
2"	39	,	32.0	39.2	45.3
2 1/2"	,	92	58	71	82
3"	,	132	92	113	131
4"	,	235	162	199	230
6"	,	530	368	452	522
8"	,	880	642	787	911
10"	,	1380	1015	1245	1440









Maximum Flow and Pressure Loss for Steel Pipes (Sch 40)

	Pipe Size	Maximum Flow (gal/min)	Velocity (ft/s)	Pressure Drop (ft/100 ft)
	2"	45	4.3	3.9
	2-1/2"	75	5.0	4.1
	3"	130	5.6	3.9
	4"	260	6.6	4.0
	6"	800	8.9	4.0
	8"	1,600	10.3	3.8
	10"	3,000	12.2	4.0

Expansion Tank Design

	Description	Rules of Thumb
	Expansion Volume	Water expands ~3.7% per 140°F rise (e.g., 60°F → 200°F)
	Expansion Tank Sizing	Size for total system volume; allow ~4% expansion volume
	Tank Type	Use closed bladder or diaphragm tank; check for bladder failure
	Relief Valve Protection	Tank absorbs expansion to prevent relief valve discharge (set ~30 psi)
	Pressure Settings	Set tank air pressure to avoid relief valve activation
	Pre-charge Pressure	Match pre-charge to system static fill pressure (12–15 psi)
	Circulator Protection	Proper tank sizing avoids pressure fluctuations harming circulator
	Location	Install tank on suction side of circulator (near boiler)

Air Elimination Devices





	Devices	Function/Rules of Thumb
	Manual Air Vents	Installed at high points; manually vent trapped air (“coin vents”)
	Automatic Air Vents	Automatically vent air; common on radiators and risers
	Float-Type Air Vents	Float closes valve with water; opens to vent air when float drops
	Fiber Disc Type Vents	Discs swell wet (close), shrink dry (open) for air venting
	Micro-Bubble Separators	Use mesh/media to capture tiny bubbles for better air removal
	Air Scoops	Deflect and collect air using baffles; older but still used
	High Point Vents	Placed at vertical run tops to vent naturally rising air
	Air Pergers	Temporary device during startup/filling to remove large air volumes

Minimum Piping Insulation

Fluid Operating Temperature Range (°F)	Insulation Conductivity		Nominal Pipe or Tube Size, in.				
	Conductivity* Btu-in/h.ft ² . °F	Mean Rating Temp., °F	<1	1 to <1-1/2	1-1/2 to <4	4 to <8	≥8
>350	0.32 to 0.34	250	4.5	5.0	5.0	5.0	5.0
251 to 350	0.29 to 0.32	200	3.0	4.0	4.5	4.5	4.5
201 to 250	0.27 to 0.30	150	2.5	2.5	2.5	3.0	3.0
141 to 200	0.25 to 0.29	125	1.5	1.5	2.0	2.0	2.0
105 to 140	0.22 to 0.28	100	1.0	1.0	1.5	1.5	1.5

Source: ASHRAE 90.1, 2019. Refer Table 6.8.3-1 for more details





Heat Emitter Sizing & Selection Criteria Table

	Emitter Type	Applications	Capacity Range (Btu/h/)	Standard Sizes (L × H × D in inches)	Key Selection Criteria
	Radiators	Residential, offices	200–600 Btu/h/ft	24–72 × 20–36 × 4–8	Room load, water temp (180°F in / 160°F out), flow rate
	Convectors	Commercial, corridors	300–1000 Btu/h/ft	24–120 × 18–36 × 6–12	Water temp, fin density, flow rate
	Baseboard Heaters	Residential, schools	500–900 Btu/h/ft	36–144 × 7–9 × 2–3	Room size, wall length, water temp
	Unit Heaters	Warehouses, garages	10,000–150,000 Btu/h	24–60 × 24–60 × 12–36	Water temp, air throw distance, space volume
	Fan Coil Units	Hotels, offices, hospitals	200–4,000 Btu/h per unit	18–60 × 12–36 × 8–18	CFM, coil capacity, external static pressure

Notes:



- Natural convectors are quieter and better for maintaining a consistent temperature. Forced convection convectors are suitable for areas requiring rapid heating or where airflow needs to be directed.
- Material Consideration: Use copper/aluminum for fast response; steel convectors for rugged environments; stainless in corrosive areas.

Installation Criteria for Heat Emitters







	Installation Criteria	Rules of Thumb
	Clearance	≥2" below emitter; keep fins clear of obstructions (furniture, covers).
	Placement Guidelines	Install under windows to counteract downdrafts; avoid drapes and heavy furniture.
	Mounting Height	4"–6" above finished floor for optimal convection and ease of cleaning.
	Placement & spacing	Near cold surfaces; space units 5–6 ft apart for uniform heating.





Pipe Sizing per loop

Size pipes based on flow rate, velocity, and convactor total Btu/h load requirements.











	Pipe Size	Number of Convectors per pipe size	Flow Rate
	1/2"	3 convectors	up to 1.5 GPM
	3/4"	8 convectors	up to 4 GPM
	1"	10–16 units	up to 8 GPM







Energy Efficiency in Hot Water System

	Design Guidance	Rules of Thumb
	Boiler Selection	Use condensing boilers ≥ 90% thermal efficiency. Ref: ASHRAE 90.1
	Hot Water Temp. Range (ΔT)	Design for $\Delta T = 20^\circ\text{F}$ typical; higher ΔT (e.g., 30–40°F) improves pump efficiency and return temp control.
	Insulation	≥ 1" thickness; use low conductivity material to reduce loss and cycling. Ref: ASHRAE 90.1, IECC
	Pipe Sizing	Pressure drop < 4 ft/100 ft; velocity 2–4 ft/s for optimal flow/noise balance.
	Installation	Shorten pipe runs; reduce elbows and fittings to limit heat loss and pressure drop.
	Zone Control	Use TRVs or zone valves to save 5–10% energy via room-level control.
	Controls	Apply outdoor reset control (per ASHRAE 90.1): <ul style="list-style-type: none"> • 180°F if OA < 20°F









	Design Guidance	Rules of Thumb
		<ul style="list-style-type: none"> • 150–180°F if OA = 20–50°F • 150°F if OA > 50°F <p>→ Saves 10–20% energy.</p>
	Energy Efficiency	Preheat domestic hot water (DHW) to reduce boiler load and improve efficiency
	Energy Efficiency	Use low-temp systems (130–140°F) to boost condensing boiler efficiency and cut heat losses
	Energy Efficiency	Design for variable flow; saves up to 50% pump energy vs. constant flow
	Thermal Storage	Use to manage peak loads, reduce boiler size, and enhance part-load performance
	Antifreeze	Use non-toxic propylene glycol for environmental safety

Heat Pumps for Heating and Cooling











	Design Factors	Rules of Thumb
	Heat Pump Function	Transfers heat via vapor compression; provides heating and cooling. Reversing valve switches refrigerant flow.
	Efficiency Metrics	HSPF: 7–13+, COP: 3–4 (air-source in mild climates).
	Heat Pump Types	ASHP (Air), GSHP (Ground), WSHP (Water).
	Minimum Efficiency Standards (USA)	ASHP: SEER ≥ 14.3, HSPF ≥ 8.2; GSHP: EER ≥ 17.1, COP ≥ 3.6. Ref: ASHRAE 90.1, DOE.
	Climate Suitability	ASHP: Mild/moderate; GSHP/WSHP: Suitable for all climates.
	Sizing Rule of Thumb	25–60 Btu/h/ft ² depending on climate/load; confirm via ACCA Manual J.
	Supplemental Heat	Required for ASHP <17°F. Use electric, gas, or oil backup.
	GSHP Loop Piping	Horizontal: 400–500 ft/ton; Vertical: 180–300 ft/ton. Use HDPE SDR11. Ref: IGSHPA.
	Zoning Considerations	Use duct dampers or separate air handlers; variable-capacity systems improve zoning.
	Controls & Thermostats	Smart thermostats, outdoor reset (GSHP), integrated backup heat. Ref: ASHRAE 90.1, IECC.
	Refrigerants	Common: R-410A; Transitioning to R-32 and R-454B (low-GWP). Ref: ASHRAE 15/34, EPA 608.

	Design Factors	Rules of Thumb
	Noise Levels	Indoor: <50 dB(A); Outdoor ASHPs: <60–70 dB(A). Ref: UL 1995.
	Ground Loop Fluids (GSHP)	20–30% propylene glycol or ethanol for freeze protection. Ref: IGSHPA.
	Lifecycle Costs	ASHP: Lower install, higher O&M in cold climates. GSHP: Higher upfront, lower long-term O&M.
	Life Expectancy	ASHP: 12–15 yrs; GSHP/WSHP: 20–25 yrs; GSHP loop: >50 yrs.
	Rebates & Incentives	Available for ENERGY STAR and high-COP systems; check local utility programs.
	Common Pitfalls	Oversizing, poor airflow, inadequate defrost, undersized loop, no backup heat.
	Codes & Standards	ASHRAE 90.1, 62.1; IECC; NEC; NFPA 70/54; IGSHPA; EPA 608; UL 1995; ASHRAE 15/34.





Air Source Heat Pump (ASHP) Design



















	Design Factors	Rules of Thumb
	ASHP Sizing	30–60 Btu/h/ft ² depending on climate and insulation.
	Design Temperatures	Heating: –5°F to 5°F (cold climates); Cooling: 95°F outdoor.
	Efficiency Targets	SEER: 14–15; HSPF2: 8.2–8.8 (≥9.5 for cold climates); COP: 3.0–4.0 @47°F, 2.0–2.5 @17°F. Ref: DOE, AHRI, ENERGY STAR v6.1
	Turndown Ratio / Modulation	Inverter systems modulate 25–100% for comfort and efficiency.
	Backup Heat	Required below 17°F; size electric resistance backup for 50–100% of peak load.
	Airflow	350–450 CFM per ton. Ref: ACCA Manual D, ASHRAE 62.1-2022
	Static Pressure (Ductwork)	≤0.5 in. w.c. for residential systems. Ref: ACCA Manual D
	Refrigerants & Line Sizes	R-410A, R-32, shifting to R-454B. Typical: 3/8" liquid, 5/8" suction (up to 50 ft). Ref: ASHRAE 15/34, EPA SNAP
	Outdoor Unit Location	Avoid wind; 12–24" clearance; mount above snowline.

Geothermal Heat Pump System Design





	Design Factors	Rules of Thumb / Benchmark
	Design Flowrate	~3 GPM per ton of cooling/heating load.
	Pipe Sizing	≤4 ft of water pressure drop per 100 ft; velocity <6 ft/s; <3 ft/s with glycol.
	Pump Selection	Select within 5% of Best Efficiency Point (BEP).
	Ground Loop Arrangement	Use multiple loops for different zones or usage patterns.
	Pump Redundancy	100% redundancy (2 pumps) or N+1 configuration (e.g., 3 pumps at 50%).
	Flow Control	Prefer impeller trimming over throttling with triple-duty valves.
	Condensation Risk	Ensure pumps/motors are rated for lowest loop temperature.
	Pipe Materials	HDPE for GSHP loops; copper or steel for WSHP; suit for <6 ft/s velocity.
	Piping for Hydraulic Control	Use reverse return for self-balancing (≤15% imbalance); direct return OK if <30% head loss or PICVs used.
	Variable Flow Requirement	Pumps >5 HP: Reduce to ≤30% at 50% flow. Pumps >10 HP: VFD required. Ref: ASHRAE 90.1-2022 §6.5.4.
	Minimum Flow Rate	Maintain ≥25% of design flow in variable flow systems.
	Two-Way Isolating Valves	Required for each heat pump to stop flow when off.
	Pump Modulation	Must match pump speed to system demand.
	Low-Frequency Operation	Avoid operation below 33% speed (20 Hz) to reduce motor and VFD wear.

Radiant Floor Systems







	Design Factors	Rules of Thumb
	Room Heat Loss	Match system output to peak load for comfort.
	Heat Output	20–35 Btu/h/ft ² (varies with floor type, insulation, water temp).
	Boiler Compatibility	Use modulating condensing boilers or heat pumps; low-temp preferred.
	Indoor Setpoint Temperature	70–72°F (21–22°C).

	Design Factors	Rules of Thumb
	Floor Surface Temperature	Max: 85°F; Ideal: 80–82°F. Bathrooms may be higher. Ref: ASHRAE.
	Flow Rate	2–4 ft/s for good heat transfer and quiet operation.
	Supply Water Temperature	90–120°F typical; lower for condensing boilers/heat pumps.
	Tube Material	PEX or PE-RT; PEX-A is most flexible and common.
	Tube Diameter	1/2" common; 5/8" or 3/4" for higher output or longer loops.
	Loop Length	Max 300 ft for 1/2" PEX; keep loops equal in length.
	Pipe Spacing	4–12 inches; tighter spacing at perimeter zones.
	Slab Thickness	4"–6" typical; place tubing in lower or middle third.
	Subfloor Insulation	Min R-10 under slab or joists.
	Slab Edge Insulation	Min R-10 rigid foam (XPS/EPS).
	Floor Covering	Tile/concrete best; carpet/wood reduce output by 20–40%. Use stable hardwood.
	Control Strategy	Use individual room zoning with actuators and thermostats; include outdoor reset.
	Manifold Location	Near zones in accessible areas to minimize piping and loss.
	Response Time	Slab: 1–3 hrs; Panel/joist: 30–60 mins.
	Expansion & Oxygen Barrier	Use oxygen barrier PEX (DIN 4726) to protect metal components.
	Glycol Use	Add 20–30% propylene glycol in freeze-prone systems.
	Life Expectancy	Tubing: 50+ yrs; Boilers/pumps: 15–20 yrs; Actuators: 10+ yrs.
	Codes & Standards	ASHRAE 90.1, IECC, IRC/IMC, NFPA 54/70, DIN 4726.
	Common Pitfalls	Poor insulation, zoning, layout, or floor material selection. Lag time must be managed.





Pipe Sizing for Radiant Floor Heating



	Factors	Rules of Thumb
	Room Size & Heat Demand	Pipe size by room/load: Small rooms → 3/8" or 5/8"; Larger/high demand → 3/4".
	Pipe Length	Max loop length by pipe size: 3/8" ≤ 200 ft; 1/2" ≤ 300 ft; 5/8" ≤ 400 ft.
	Pipe Spacing	Depends on flow/temp/comfort: 3/8" = 4–6"; 5/8" = 6–8"; ≥3/4" = >10".
	Floor Type	High conductivity (tile/concrete) → wider spacing; Low conductivity (wood/carpet) → closer spacing.
	Flow Velocity	Keep flow ≤1 m/s (3 ft/s) to prevent noise and pipe wear.





Common Pitfalls

	Common Pitfalls	Rules of Thumb
	Improper Sizing	Avoid oversizing, causes short cycling, low efficiency, and early equipment failure.
	Undersized Furnaces	Ensure correct sizing, undersized units can't meet heating demand, causing discomfort.
	Poor Ductwork Design/Installation	Design for proper airflow, sizing, and sealing, leaks and restrictions reduce system performance.
	Incorrect Venting	Use code-compliant venting by category, wrong venting risks CO hazards and equipment damage.
	Inadequate Combustion Air	Follow NFPA 54/IFGC air requirements, lack of combustion air causes CO buildup and poor furnace operation.
	Skipping Professional Installation/Startup	Always use professional installation and commissioning to ensure safety and efficiency.

Standard Hydronic Equations

	Parameters	Equations and Rules of Thumb
	Building Heat Loss (Q) (Rough Estimate)	<p>Equation: $Q = U \times A \times \Delta T$ (Btu/h)</p> <p>U = Overall heat transfer coefficient (Btu/h-ft²-°F), A = Area (ft²), ΔT = Temperature difference (°F).</p> <p>Rule: 20–60 Btu/h-ft² conditioned area (varies by climate & insulation)</p> <p>Standards: ASHRAE Handbook, Fundamentals 2021, ACCA Manual J</p>
	Boiler Sizing	<p>Size boiler output (Net Btu/h) to be 1.15 to 1.25 times the calculated building heat loss. (The extra capacity accounts for pick-up load and extreme conditions, but gross oversizing reduces efficiency).</p> <p>Rule of Thumb: Residential: 30–60 Btu/h per ft² and commercial: Detailed Manual N or block load required.</p>
	Hydronic Flow Rate (GPM)	<p>Equation: $GPM = Q / (500 \times \Delta T)$</p> <p>Q = Heat load (Btu/h), ΔT = Temperature drop (°F), 500 = Constant for water (8.33 lb./gal × 60 min/h).</p> <p>Rule: ~1 GPM per 10,000 Btu/h @ ΔT=20°F</p> <p>Standards: ASHRAE HVAC Systems 2020, Hydronics Institute I=B=R Manual</p>
	Pipe Friction Loss, inches of water gauge (in-WG)	<p>Equation: $\Delta P = f \times (L/D) \times (\rho \times V^2/2g)$</p> <p>ΔP = Pressure-drop (in-WG), f = Friction factor, L = Pipe length (ft), D = Pipe diameter (ft), ρ = Density (lb./ft³), V = Velocity (ft/s), g = 32.2 ft/s².</p> <p>Rule: 1–4 ft H₂O per 100 ft pipe (~12–48 in-WG)</p> <p>Standards: ASHRAE Handbook Fundamentals 2021, UPC 2021</p>
	Pump Head (in-WG)	<p>Calculation: Sum of friction losses in the longest piping run (index circuit) + pressure drop through all components (boiler, heat emitters, valves, fittings).</p>

	Parameters	Equations and Rules of Thumb
		<p>Equation: Total Head = Friction Loss + Static Head + Fitting Losses (in-WG).</p> <p>Residential range: 6–20 ft head (~72–240 in-WG)</p> <p>Standards: Hydronics Institute I=B=R Manual, ASHRAE 90.1-2022 §6.5.4</p>
	Heat (Radiator/Baseboard) (Btu/h) Emitter Output	<p>Equation: $Q = U \times A \times \text{LMTD}$</p> <p>LMTD = Log Mean Temperature Difference (°F).</p> <p>Rule: Baseboards ~500–600 Btu/h per ft at 180°F water, 20°F ΔT. Radiators ~150–200 Btu/h per section at 180°F</p> <p>Check manufacturer specs</p>
	Pipe Sizing (D) in inches	<p>$\text{GPM} = 2.45 \times v \times (D)^2$</p> <p>Or $D = \sqrt{\frac{0.41 * \text{GPM}}{v}}$</p> <p>GPM is gallons per minute of volumetric flowrate, v is the desired velocity of the fluid in feet per second (fps), D is the internal diameter of the pipe in inches and 2.45 is the conversion factor to get results in GPM, with pipe diameter in inches and velocity in feet per second (fps).</p> <p>Ideal velocity: 2-4 ft/s in smaller pipes (up to 2") and up to 8-10 ft/s may be acceptable in larger mains and unoccupied areas.</p> <p>Rule: ¾" pipe for 10–15,000 Btu/h; 1" for 15–30,000 Btu/h at 2–4 ft/s velocity</p> <p>Standards: ASHRAE Handbook, HVAC Systems 2020 (Chapter 13); UPC 2021, Appendix A.</p>
	Expansion Tank Sizing	<p>Equation: $V_t = [(V_s \times E_w) / (P_a / P_f - P_a / P_o)]$</p> <p>$V_t$ = Tank volume (gal), V_s = System volume (gal), E_w = Water expansion factor, P_a = Atmospheric pressure (psia), P_f = Fill pressure (psia), P_o = Operating pressure (psia).</p> <p>Rule: 1–2 gal per 10,000 Btu/h for residential diaphragm tanks</p>

	Parameters	Equations and Rules of Thumb
		<p>Thermal expansion: ~0.02 gal/ft³ per 40°F rise</p> <p>Standards: ASME Boiler & Pressure Vessel Code Sec VIII, UPC 2021 Sec 608</p>
	Air Separator Sizing	<p>Equation: $Q = A \times V$</p> <p>Q = Flow rate (GPM), A = Cross-sectional area of separator inlet (ft²), V = Velocity through separator (ft/s).</p> <p>Rules: Velocity: 4–8 ft/s inlet; max 10 ft/s; Size to flow rate: e.g., 1" pipe for 15–30,000 Btu/h, 2" pipe for 50–100,000 Btu/h; Pressure drop <0.5 in-WG; Install supply side after boiler</p> <p>Standards: ASHRAE Handbook, HVAC Systems 2020 (Chapter 13), UPC 2021, Chapter 6; CIBSE Domestic Heating Design Guide 2021 (Section 5.7).</p>
	Make-up Water Pressure (Hydronic)	<p>Fill pressure = (Static height ft / 2.31) + 4–5 psi</p> <p>Example: 23 ft system → ~14 psi fill pressure</p> <p>Must be below relief valve setting</p> <p>Conversion: 1 psi = 27.7 in-WG</p>
	Airflow for Forced Air Heating (Approx.)	<p>$Q = 1.08 \times \text{CFM} \times \Delta T \rightarrow \text{Btu/h (for air)}$</p> <p>Where: CFM = Airflow rate (Cubic Feet per Minute); Q = Sensible heat load (Btu/h), ΔT = Temperature difference between supply air and room air (°F) (ranges 20-60°F for heating) and 1.08 is a constant for air's density and specific heat.</p>
	Converting Pressure Units	<p>1 psi ≈ 2.31 ft H₂O; 1 psi ≈ 27.7 in-WG; 1 ft H₂O = 0.433 psi; 1 ft H₂O = 12 in-WG</p>

Key Notes:

- Heating choice depends on application, fuel availability, safety needs, space constraints, climate, building layout, and budget.
- Sizing: Btu/h/ft² varies by climate (e.g., 30 for mild, 60 for cold) and insulation.
- Gas dominates; electric suits small residential/temporary spaces; oil is common in rural areas without gas lines.

Disclaimer: The rules, metrics, and guidelines in this course are based on the author's experience and established engineering practices. These are not universal benchmarks, and specific values may vary depending on operating conditions and other factors. Proper design and engineering analysis based on manufacturer recommendations are essential for desired results. This document is a live resource and will be updated as new information becomes available.

Annexure 2: Vent Sizing Methodology for Natural Vent (Type B) Using NFPA 54

Sizing a natural vent (e.g., Type B double wall) for a gas furnace follows NFPA 54/ANSI Z223.1 capacity tables to ensure safe flue gas removal. It involves matching the vent diameter and height to the furnace's Btu/h input, vent layout, and draft type (natural draft for Category I). Below is a simple step-by-step guide with an example.

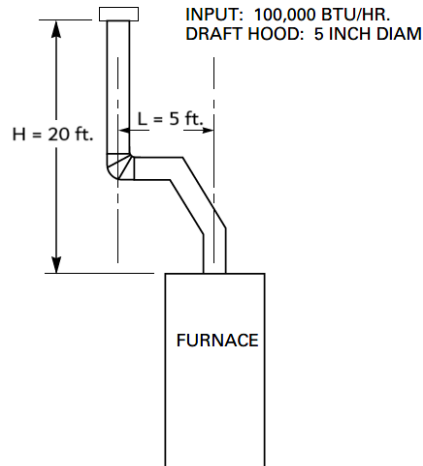

Vent Sizing Methodology (Natural Draft – Category I Furnace)

1) Identify Furnace Specifications:

- Input Capacity: e.g., 100,000 Btu/h
- Draft Type: Natural draft (Category I)
- Flue Collar Size: e.g., 5 inches

2) Determine Vent Configuration:

- Total Vent Height (H): Vertical distance from flue collar to vent cap (e.g., 20 ft)
- Lateral Length (L): Horizontal connector length to vertical vent (e.g., 5 ft)

3) Select NFPA 54 Sizing Table:

- Use Table 13.1(a) for Type B double-wall vents with Type B connectors (single appliance, natural draft)
- Table provides max Btu/h capacity by vent diameter, height (H), and lateral length (L)

4) Match Vent Capacity to Furnace Input:

- Find a vent diameter where "NAT Max" \geq furnace input at given H and L
- Ensure vent diameter is compatible with flue collar (downsizing allowed if $H \geq 10$ ft and permitted by local code)

5) Adjust for Installation Constraints:

- Max 2 elbows; each extra 90° elbow = 10% reduction in capacity
- Maintain upward lateral pitch: ¼ inch per foot

6) Verify Code Compliance:

- Per NFPA 54 Section 7.2.1, ensure continuous positive flow to safely exhaust all combustion gases outdoors

Example Calculation

- Scenario: Size a Type B vent for a natural draft furnace.
- Furnace Input: 100,000 Btu/h.
- Flue Collar: 5 in.
- Total Vent Height (H): 20 ft.
- Lateral Length (L): 5 ft.
- Draft: Natural (Category I).

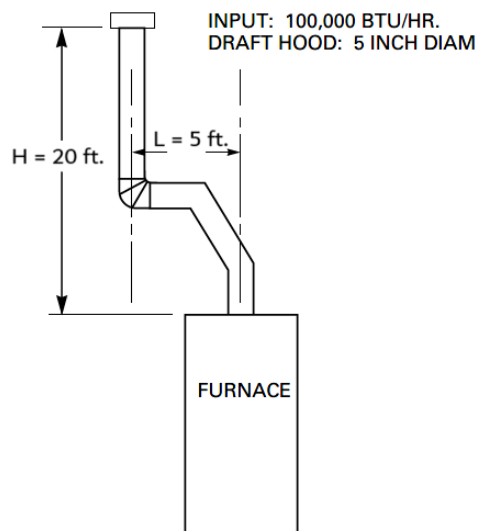

Steps

Refer to NFPA 54 Table 13.1(a) (simplified excerpt):

Height (H)	Lateral (L)	Diameter (in.)	NAT Max (Btu/h)
20 ft	0 ft	4	89,000
20 ft	0 ft	5	164,000
20 ft	5 ft	4	84,000
20 ft	5 ft	5	155,000
20 ft	10 ft	5	150,000

Match Input to Capacity:

At H = 20 ft, L = 5 ft:

4 in.: 84,000 Btu/h (too small).

5 in.: 155,000 Btu/h (>100,000 Btu/h, sufficient).

Check Flue Collar:

5 in. vent matches 5 in. collar; no downsizing needed ($H \geq 10$ ft allows it if code permits).

Adjustments:

Assume 1 elbow (within 2 max); no capacity reduction needed.

Lateral pitch: $5 \text{ ft} \times \frac{1}{4} \text{ in./ft} = 1.25 \text{ in. rise}$ (meets requirement).

Result

Vent Size: 5 in. diameter Type B vent.

Verification: 155,000 Btu/h capacity exceeds 100,000 Btu/h input, ensuring all flue gases are exhausted per NFPA 54.

Annexure 2: Vent Sizing Methodology for Manifoldd Multiple Vent System Using NFPA 54

When venting multiple furnaces on the same floor through a shared vent (manifold), both the individual connectors and the common vent must be properly sized. This is typical for Category I natural draft furnaces (65–83% AFUE) that rely on chimney buoyancy (–0.02 to –0.05 in. WG) without mechanical exhaust.

The acronym “Nat + Nat” refers to a common vent serving two natural draft appliances.

Use NFPA 54 Table 13.4(b) to find the maximum allowable Btu/h capacity for such setups.

A concise sizing method and example follow below.

Manifoldd Vent Sizing Methodology – Category I (Natural Draft Furnaces)

1) Identify Appliance Details

- Furnace Inputs: e.g., 45,000 & 100,000 Btu/h
- Draft Type: Natural draft (Category I)
- Flue Collar Sizes: e.g., 4 in. and 5 in.

2) Define Vent Layout

- Vent Height (H): Vertical distance from highest draft hood to vent cap (e.g., 18 ft)
- Connector Rise: Vertical from draft hood to manifold (e.g., 1 ft, 2 ft)
- Connector Lengths: Horizontal to manifold (e.g., 5 ft each)
- Manifold Length: Max 10 ft or 50% of H; slope upward ¼ in./ft

3) Select Relevant NFPA 54 Tables

- Table 13.4(a): Vent connector sizing (single/multiple appliances)
- Table 13.4(b): Common vent sizing (multiple appliances)
- Use columns labeled “Nat + Nat” if all appliances are natural draft

4) Size Vent Connectors

- Match connector diameter to input using Table 13.4(a) for the given H and rise
- Limit connector length to 1.5 ft per inch diameter (e.g., 4 in. = 6 ft max); derate capacity 10%/ft if exceeded

5) Size Common Vent & Manifold

- Total Input: Add furnace inputs (e.g., 145,000 Btu/h)
- Use Table 13.4(b) to select common vent size where capacity \geq total input
- Manifold: Tapered or constant; limit length per above; ensure upward slope

6) Account for Constraints

- Max 2 elbows per connector/vent; reduce capacity 10% per extra 90°
- Manifold connections must be staggered, not on the same horizontal plane

7) Verify Code Compliance

- Per NFPA 54 §7.2.1, ensure positive flow and no flue gas spillage or dilution

Example

Scenario: Size a manifolded vent for two natural draft furnaces (Category I).

- Furnace 1: 45,000 Btu/h, 4 in. collar, 1 ft rise
- Furnace 2: 100,000 Btu/h, 5 in. collar, 2 ft rise
- Vent Height: 18 ft (min. from highest draft hood to vent cap)
- Lateral Lengths: 5 ft each (to manifold)
- Manifold: 10 ft (horizontal extension, tapered)
- Draft: Natural draft (Nat + Nat)
- Elbows: Assume 1 per connector + 1 at manifold entry (adjust if >2).

Steps

Refer to NFPA 54 Tables (simplified excerpts):

Table 13.4(a) (Vent Connector Capacity, Nat + Nat):

Height (H)	Rise (ft)	Diameter (in.)	Capacity (Btu/h)
15 ft	1 ft	4	37,000
15 ft	1 ft	5	72,000
15 ft	2 ft	4	42,000
15 ft	2 ft	5	82,000

Table 13.4(b) (Common Vent Capacity, Nat + Nat):

Height (H)	Diameter (in.)	Capacity (Btu/h)
15 ft	5	117,000
15 ft	6	184,000
20 ft	5	131,000
20 ft	6	207,000

Note: Interpolate for H = 18 ft (between 15 ft and 20 ft).

Size Vent Connectors:

Furnace 1 (45,000 Btu/h, 4 in. collar, 1 ft rise, 5 ft lateral):

At H = 15 ft, 1 ft rise: 4 in. = 37,000 Btu/h (sufficient); 5 in. = 72,000 Btu/h (oversized).

Check lateral: 4 in. ≤ 6 ft (1.5 × 4 in.), OK; no derating (5 ft < 6 ft).

Adjust for H = 18 ft: ~39,000 Btu/h (interpolate, +4% from 15 ft).

4 in. connector used (39,000 > 45,000, but closest; check below).

Furnace 2 (100,000 Btu/h, 5 in. collar, 2 ft rise, 5 ft lateral):

At H = 15 ft, 2 ft rise: 5 in. = 82,000 Btu/h (>100,000, sufficient); 4 in. = 42,000 Btu/h (too small).

Check lateral: 5 in. \leq 7.5 ft (1.5×5 in.), OK; no derating (5 ft < 7.5 ft).

Adjust for H = 18 ft: ~85,000 Btu/h (interpolate, +4% from 15 ft).

5 in. connector used (85,000 > 100,000, sufficient).

Size Common Vent and Manifold:

Total input = 45,000 + 100,000 = 145,000 Btu/h.

Interpolate for H = 18 ft:

5 in.: 15 ft = 117,000, 20 ft = 131,000; 18 ft = 117,000 + ($3/5 \times 14,000$) = 125,400 Btu/h.

6 in.: 15 ft = 184,000, 20 ft = 207,000; 18 ft = 184,000 + ($3/5 \times 23,000$) = 197,800 Btu/h.

6 in. common vent (197,800 > 145,000, sufficient); must be \geq largest connector (5 in.), so 6 in. OK.

Manifold: Tapered, 10 ft max, slope $1/4$ in./ft (10 ft \times $1/4$ in./ft = 2.5 in. rise).

Adjust for Elbows:

Assume 1 elbow per connector (5 ft lateral), 1 at manifold; total 3 elbows.

Derate common vent: $197,800 - (2 \times 10\% \times 197,800) = 197,800 - 39,560 = 158,240$ Btu/h (>145,000, OK).

Verify Compliance:

6 in. common vent, 4 in./5 in. connectors handle 145,000 Btu/h, ensuring positive flow per NFPA 54.

Result

Connectors: 4 in. for 45,000 Btu/h, 5 in. for 100,000 Btu/h.

Common Vent: 6 in. diameter (158,240 Btu/h after derating).

Manifold: Tapered, 10 ft, $1/4$ in./ft slope.

All meet NFPA 54 for natural draft, preventing spillage or dilution.